

shindaiwa[®]

Operator's Manual RS600 Broadcast Spreader

INTRODUCTION

Specifications, descriptions and illustrative material in this literature are as accurate as known at the time of publication, but are subject to change without notice. Illustrations may include optional equipment and accessories, and may not include all standard equipment.



Read and understand all provided literature. Literature contains specifications and information for safety, operation, maintenance, storage, and assembly specific to this product. Scan QR codes for more information.



For additional literature, including safety manuals where applicable, or questions regarding terms used in this manual, visit:

<https://www.echo-usa.com/manuals>

OR



<https://www.shindaiwa-usa.com/manuals>

SERVICING INFORMATION

Parts and Serial Number

Genuine SHINDAIWA Parts and Assemblies for your SHINDAIWA products are available only from an Authorized SHINDAIWA Dealer. When you do need to buy parts **always** have the Model Number and Serial Number of the unit with you. For future reference, write them in the space provided below.

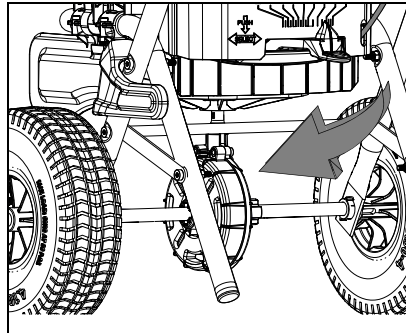

Model No. _____ Serial No. _____

Service

Service of this product during the warranty period must be performed by an Authorized SHINDAIWA Service Dealer. For the name and address of the Authorized SHINDAIWA Service Dealer nearest you, ask your retailer or call: 1-877-986-7783. Dealer information is also available on WWW.SHINDAIWA-USA.COM. When presenting your unit for Warranty service/repairs, proof of purchase is required.

Consumer Product Support

If you require assistance or have questions concerning the application, operation or maintenance of this product you may call the SHINDAIWA Consumer Product Support Department at 1-877-986-7783 from 8:00 am to 5:00 pm (Central Standard Time) Monday through Friday. Before calling, please know the model and serial number of your unit.

Product Registration

To ensure trouble free warranty coverage it is important that you register your SHINDAIWA equipment on-line at WWW.SHINDAIWA-USA.COM or by filling out the product registration sheet included in this manual. Registering your product confirms your warranty coverage and provides a direct link between you and ECHO if we find it necessary to contact you.

Additional Literature

In addition to finding information online, information is available from your Authorized Shindaiwa Service Dealer, or by contacting ECHO Incorporated, 400 Oakwood Road, Lake Zurich, IL 60047, 1-800-432-ECHO (3246).

SAFETY

Safety Information **WARNING**

Carefully read these instructions before use. Improper use or failure to follow instructions can result in product failure or injuries. For safe use of this product you must read and follow all instructions before using.

 **WARNING**

Cancer and Reproductive Harm
www.P65Warnings.ca.gov

 **WARNING**

- ◆ Do not allow anyone to operate the broadcast spreader without proper instructions.
- ◆ Do not permit children to operate the broadcast spreader.
- ◆ Wear all personal protective equipment recommended by chemical manufacturer.
- ◆ Read and follow the chemical label instructions and warnings for handling and applying the chemicals you plan to spread – application settings provided are only a guideline.

DESCRIPTION

Locate the safety decal(s) on your unit. Make sure the decal(s) is legible and that you understand and follow the instructions on it. If a decal cannot be read, a new one can be ordered from your dealer. The safety decal is for example only. Your label may appear slightly different.

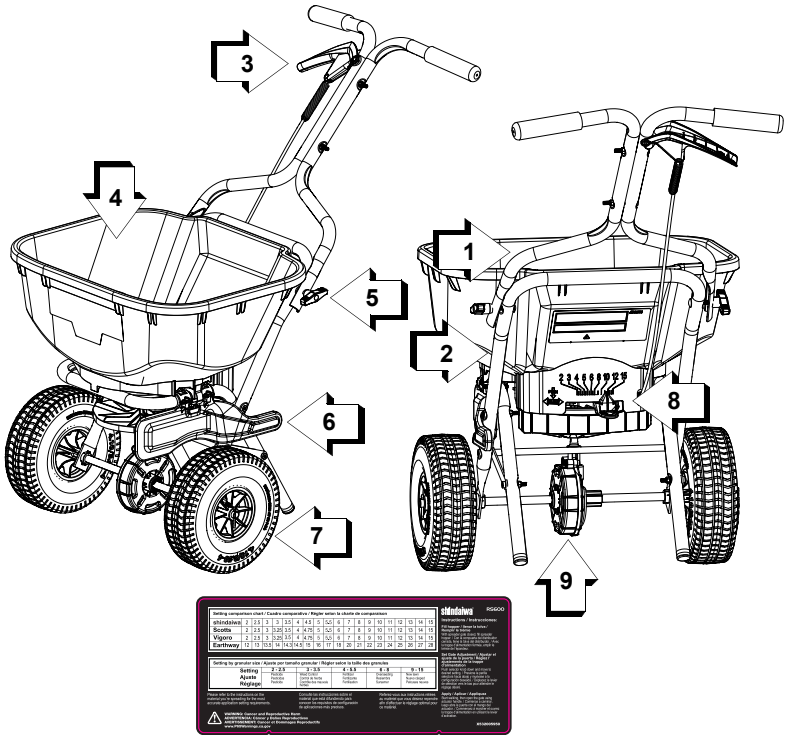

- 1 Top Handle Bracket
- 2 Bottom Handle Bracket
- 3 Actuator Handle
- 4 Hopper
- 5 Handle Assembly Wing Nut
- 6 Side Deflector
- 7 Wheels
- 8 Gate Adjuster
- 9 Gear Case

CONTENTS

The product you purchased has been partially factory pre-assembled for your convenience. Due to packaging restrictions, some assembly may be necessary.

After opening the carton, check for damage. Immediately notify your retailer or Dealer of damaged or missing parts. Use the contents list to check for missing parts.

- 1 Broadcast Spreader Assembly
- 2 Carriage Bolts
- 2 Wing Nuts
- 1 Quick Start Guide

ASSEMBLY

Install Handle Brackets

1. Align holes in top handle bracket (A) with holes in bottom handle bracket (B).

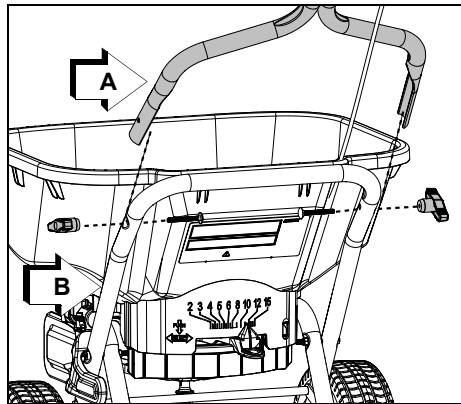

- Secure handle brackets with wing nuts (C) and carriage bolts (D) on each side.

Note: Attach each side loosely before tightening brackets securely.

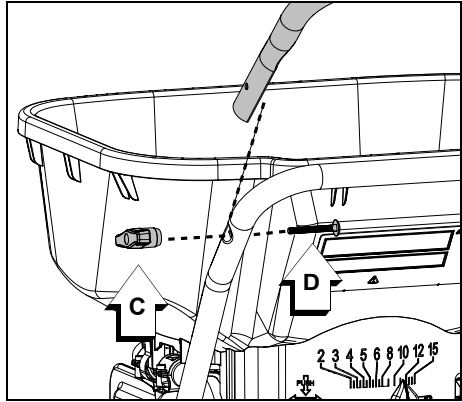

NOTICE

Assure control cable is routed behind handle brackets.

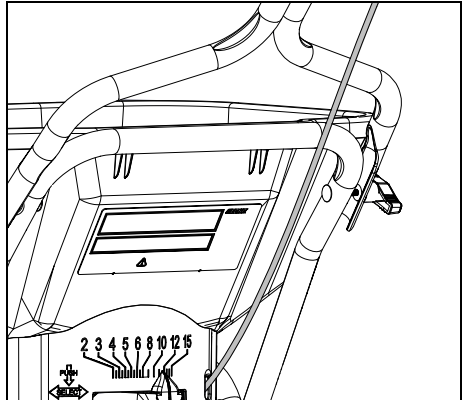

Check Tire Pressure

NOTICE

Tires should be inflated to 15 psi. Assure tire pressure does not exceed 30 psi.

OPERATION

Application Instructions

CAUTION

TIP HAZARD. Unit can tip on uneven ground. Always fill hopper on flat ground, and keep bystanders away. Otherwise personal injury can result.

1. Fill Hopper

Release actuator handle (A) to close gate. Fill hopper.

Note: Fill hopper in an area that won't be damaged by spilled product.

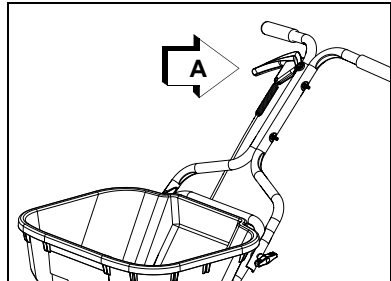

2. Set Gate Adjustment

Push gate adjuster (B) down and move to best application setting (see chart below). Pull adjuster upward to lock in place.

Note: Gate adjustment settings should only be used as a general guideline for application. Refer to instructions on material you are spreading for most accurate application setting requirements.

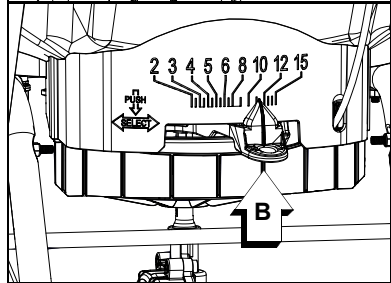

3. Application

A. Lower edge guard (C) and make perimeter pass to protect non-lawn areas. Pull actuator handle to open gate while spreading.

B. Raise edge guard. Make parallel internal passes to ensure even coverage.

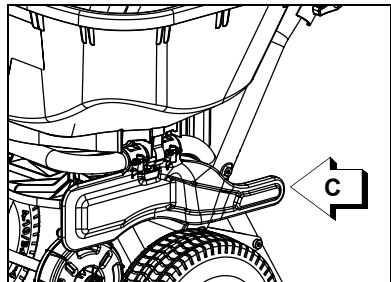

| Setting comparison chart / Cuadro comparativo / Régler selon la charte de comparaison | | | | | | | | | | | | | | | | | | | |
|---|----|-----|------|------|------|------|------|----|-----|----|----|----|----|----|----|----|----|----|----|
| Shindaiwa | 2 | 2.5 | 3 | 3 | 3.5 | 4 | 4.5 | 5 | 5.5 | 6 | 7 | 8 | 9 | 10 | 11 | 12 | 13 | 14 | 15 |
| Scotts | 2 | 2.5 | 3 | 3.25 | 3.5 | 4 | 4.75 | 5 | 5.5 | 6 | 7 | 8 | 9 | 10 | 11 | 12 | 13 | 14 | 15 |
| Vigoro | 2 | 2.5 | 3 | 3.25 | 3.5 | 4 | 4.75 | 5 | 5.5 | 6 | 7 | 8 | 9 | 10 | 11 | 12 | 13 | 14 | 15 |
| Earthway | 12 | 13 | 13.5 | 14 | 14.3 | 14.5 | 15 | 16 | 17 | 18 | 20 | 21 | 22 | 23 | 24 | 25 | 26 | 27 | 28 |

| Setting by granular size / Ajuste por tamaño granular / Régler selon la taille des granules | | | | | |
|---|-------------------------|---|---|---------------------------------------|---|
| Setting Ajuste Réglage | 2 - 2.5 | 3 - 3.5 | 4 - 5.5 | 6 - 8 | 9 - 15 |
| | Pesticide Pesticidas | Weed Control Control de hierba Contrôle des mauvaises herbes | Fertilizer Fertilizante Fertilisation | Overseeding Reasembra Sursemenc | New lawn Nuevo césped Pelouses neuves |

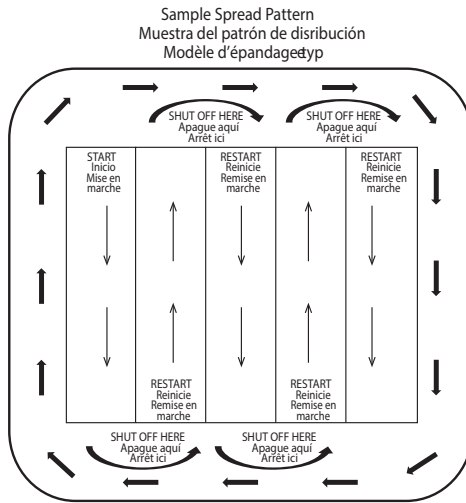

MAINTENANCE

Clean Spreader

NOTICE

Avoid spraying gear case directly, and do not use a pressure washer on spreader.

1. Wash spreader with a garden hose after each use.

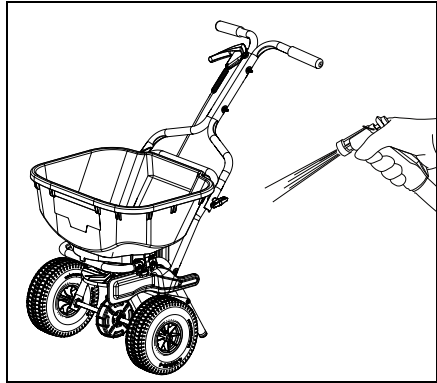

Check Tire Pressure

NOTICE

Tires should be inflated to 15 psi. Assure tire pressure does not exceed 30 psi.

Replacing Control Cable

1. Remove Shield (A).
2. Turn gate (B) clockwise to relieve tension on cable.

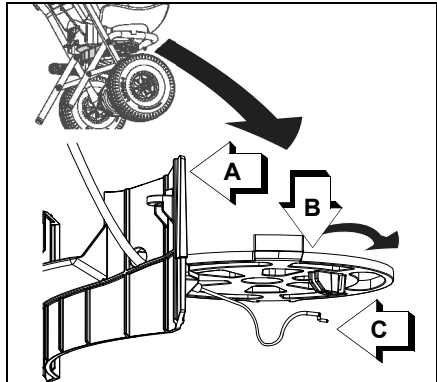

- 3. Remove cable S hook (C) from gate.

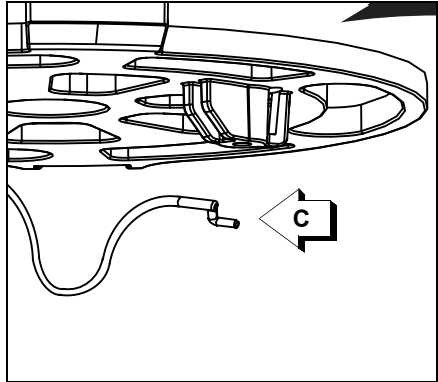

- 4. Remove upper handle bracket from lower handle bracket.

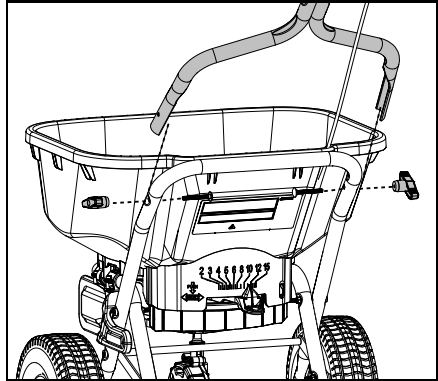

- 5. Remove bolts (D) and separate handle halves.
- 6. Install new handle half with control cable assembly.
- 7. Re assemble spreader components.

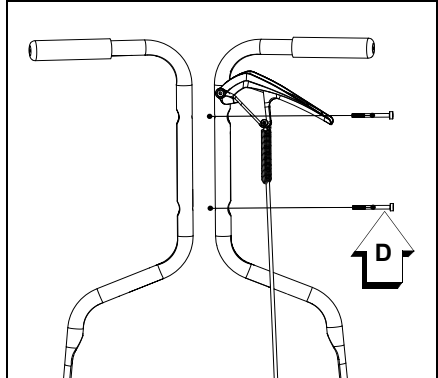

NOTICE

Assure control cable is routed behind handle brackets.

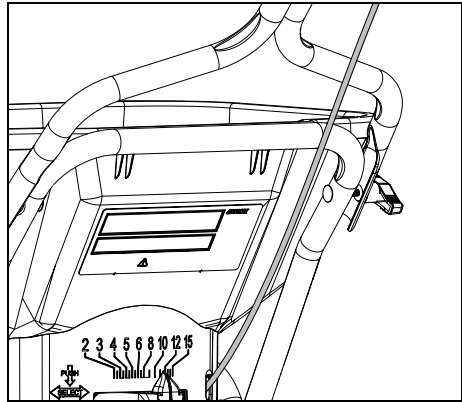

SPECIFICATIONS

| MODEL | RS600 |
|-------------------------|-------------------------------|
| Length | 959 mm (37.75 in.) |
| Width | 584 mm (23 in.) (|
| Height | 794 mm (31.25 in.) |
| Weight | 10.2 kg (22.4 lb.) |
| Capacity | |
| Weight | 27.2 kg (60lb.) |
| Volume | 36.8 L (1.3 ft ³) |
| Loading Height | 584 mm (23 in.) |
| Wheels and Tires | |
| Tire Diameter | 254 mm (10in.) |
| Tire Type | Pneumatic |
| Recommended Pressure | 103.4 kPa (15 psi) |

PRODUCT REGISTRATION

Thank you for choosing Shindaiwa Power Equipment

Please go to <http://www.shindaiwa-usa.com> to register your new product on-line. It's **FAST** and **EASY!** NOTE: your information will never be sold or misused by ECHO, Incorporated. Registering your purchase enables us to contact you in the unlikely event of a service update or product recall, and verifies your ownership for warranty consideration.

If you do not have access to the Internet, you can complete the form below and mail to:

***ECHO Incorporated, Product Registration, PO Box 1139,
Lake Zurich, IL 60047.***

shindaiwa® PRODUCT REGISTRATION CARD : TARJETA DE REGISTRO : CARTE D'ENREGISTREMENT DU PRODUIT

ONLINE OPTION: Register online and save a stamp! You will be alerted of product updates special offers. Simply go to: www.shindaiwa-usa.com

OPCIÓN POR INTERNET: Regístrese en la página web y ahorre una estampilla! Le alertarán sobre actualizaciones del producto y/o se le enviara información sobre los nuevos productos Shindaiwa y las ofertas especiales. Simplemente visite: www.shindaiwa-usa.com

OPTION EN LIGNE: Enregistrez en ligne et épargnez un timbre! Vous serez alerté des mises à jour de produits ainsi que les offres spéciales. Simplement visitez le: www.shindaiwa-usa.com

Please Print : Por Favor Enscriba Con Letra De Molde : En Lettre Carré S.V.P.

Confidential: Information provided will not be shared or sold

Purchaser's Name : Nombre del Comprador : Nom de l'acheteur

Address : Dirección : Adresse

City : Ciudad : Ville State : Estado : Zip Code : Código Postal : Code Postal

E-Mail Address : Dirección De Correo Electrónico : Courrier Électronique

Phone Number : Número De Teléfono : Téléphone Date of Purchase : Fecha de la Compra : Date de l'achat

Where Purchased : Nombre del Almacén donde fue Comprado : Lieu d'achat

Model Number : Número del Modelo : No. de modèle Serial Number : Número de Serie : No. de série

Registering your purchase enables us to contact you in the unlikely event of a service update or product recall and verifies your ownership in the event of loss. El registrar su compra nos permite estar en contacto con usted en caso de cualquier evento de actualización de servicio o de llamado de atención de un producto. El registro de su compra nos permite estar en contacto con usted en caso de cualquier evento de actualización de servicio o de llamado de atención de un producto. L'enregistrement de votre achat nous permettra de vous contacter dans le cas improbable de modifications des instructions d'entretien ou de rappel du produit et vérifier que vous êtes le propriétaire en cas de vol ou de perte.

Primary use of tool: Professional Homeowner Rental Equip.
 Uso primario de la herramienta: Profesional Dueño de casa Alquiler
 Usage principal: Profesional Residential Location
 Do you wish to receive periodic Shindaiwa product information and special offers by e-mail? Yes No
 ¿Desea usted recibir información periódica y ofertas especiales por correo electrónico sobre el producto Shindaiwa? Yes No
 Souhaitez-vous recevoir périodiquement de l'information sur les produits Shindaiwa et les offres spéciales par courrier électronique? Oui Non
 Did you visit the Shindaiwa website before purchasing your product?
 Yes No
 Visitó usted la página web Shindaiwa antes de comprar su producto?
 Si No
 Avez-vous visité le site d'Shindaiwa avant de procurer votre produit?
 Oui Non

What factor(s) most influenced your purchase?

Performance Dealer
 Reliability Price
 Friend/Family Brand Prior Experience Quality
 Warranty
 ¿Qué factor(es) influyó más en su compra?
 Funcionamiento Precio Distribuidor
 Confiablez Experiencia Anterior Calidad
 Amigo/Familia Marca Garantía

Quel facteur (facteurs) vous a influencé le plus?

Performance Prix
 Fiabilité Expérience Qualité
 Ami/Famille Marque

1.877.966.7783

www.shindaiwa-usa.com

X7571120102 05-2012

N2950001001 - N29500999999

shindaiwa[®]

ECHO INCORPORATED

400 Oakwood Road

Lake Zurich, IL 60047

www.shindaiwa-usa.com