

SHINDAIWA OWNER'S/OPERATOR'S MANUAL

HT235 HEDGE TRIMMER

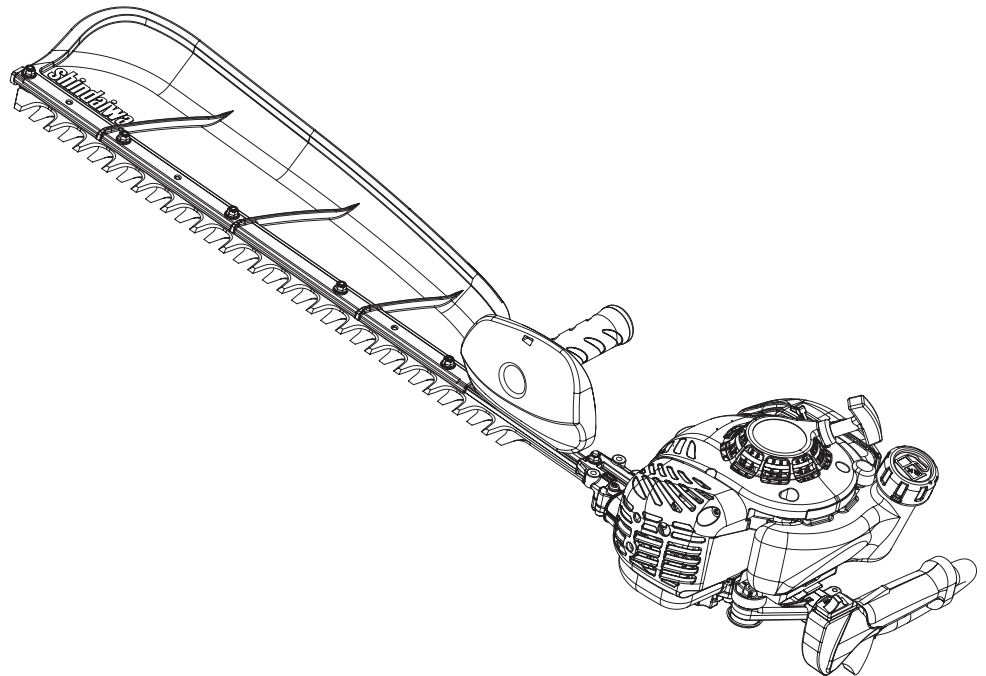

IMPORTANT!

This product complies with CAN ICES-2/NMB-2



WARNING!

Minimize the risk of injury to yourself and others! Read this manual and familiarize yourself with the contents. Always wear eye and hearing protection when operating this unit.

Introduction

The Shindaiwa HT235 Hedge Trimmer has been designed and built to deliver superior performance and reliability without compromise to quality, comfort, or durability.

Shindaiwa high performance engines represent the leading edge of air-cooled engine technology, delivering exceptionally high power at remarkable low displacement and weight. As an owner/operator, you'll soon discover for yourself why Shindaiwa is simply in a class by itself!

IMPORTANT!

The information contained in this manual describes units available at the time of publication.

While every attempt has been made to give you the very latest information about your Shindaiwa product, there may be some differences between your HT235 hedge trimmer and what is described here.

ECHO Inc. reserves the right to make changes to products without prior notification, and without obligation to make alterations to units previously manufactured.



WARNING!

The engine exhaust from this product contains chemicals known to the State of California to cause cancer, birth defects or other reproductive harm.

IMPORTANT!

The operational procedures described in this manual are intended to help you get the most from your unit, and to protect you and others from harm. These procedures are guidelines for safe operation under most conditions, and are not intended to replace any safety rules and/or laws that may be in force in your area.

If you have questions regarding your HT235 hedge trimmer, or if you do not understand something in this manual, your Shindaiwa dealer will be glad to assist you. You may also contact Shindaiwa at the address printed on the back of this manual.

Attention Statements



DANGER!

A statement preceded by the triangular attention symbol and the word "DANGER" contains information that should be acted upon to prevent serious injury or death.



WARNING!

A statement preceded by the triangular Attention Symbol and the word "WARNING" contains information that should be acted upon to prevent serious bodily injury.

CAUTION!

A statement preceded by the word "CAUTION" contains information that should be acted upon to avoid damaging your unit.

IMPORTANT!

A statement preceded by the word IMPORTANT is one that possesses special significance.

NOTE:

A statement preceded by the word "NOTE" contains information that is handy to know and may make your job easier.



Read and understand owner's manual.



Wear eyes, ears and head protection.



Wear foot protection and gloves



Finger severing.



Do not operate without guards in place.



Beware of high temperature areas.



Keep bystanders at least 4.5 meters (15 feet) away.



LOOK BEFORE YOU PUMP!

Ethanol Percentage

0% - 10% 15% - 30% - 50% - 85%

USE E10 OR LESS FUEL

Do not use any fuel containing greater than 10 percent ethanol (E10) in this equipment. It may cause damage or failure and is prohibited by Federal Law.

For Details, see the "Fuel" Section of your Operators Manual



WARNING!

Cancer and Reproductive Harm www.P65Warnings.ca.gov

Contents

	PAGE		PAGE		PAGE
Introduction.....	2	Unit Description	6	Maintenance and Adjustments	11
Attention Statements	2	Mixing Fuel	7	Long Term Storage.....	17
General Safety Instructions	3	Filling the Fuel Tank.....	8	Troubleshooting Guide	18
Safety Equipment and Labels.....	5	Starting Procedure.....	8	Warranty Statement	21
Specifications	5	Operation.....	10		
Emission Control	6	Stopping the Engine	10		

General Safety Instructions

Work Safely

Shindaiwa hedge trimmers operate at very high speeds and can do serious damage or injury if they are misused or abused. Never allow a person without training or instruction to operate your unit!



WARNING!

Never make unauthorized attachment installations.

Stay Alert

You must be physically and mentally fit to operate this unit safely.



WARNING!



Never operate power equipment of any kind if you are tired or if you are under the influence of alcohol, drugs, medication or any other substance that could affect your ability or judgement.



WARNING!

Minimize the Risk of Fire!

ALWAYS check unit for fuel leaks before use. Check for leaks around fuel tank cap while refueling. If fuel leaks are found immediately stop using the unit. Fuel leaks must be repaired before using unit.

ALWAYS move the unit to a place well away from a fuel storage area or other readily flammable materials before starting the engine.

WORK SAFELY!

Always wear close-fitting clothing. Gloves offer added protection and are strongly recommended. Do not wear clothing or jewelry that could get caught in machinery.

Never allow children to use the unit. Avoid operating near bystanders.

Always wear eye, ear, head, and hand protection while operating this unit!

Always grip support handle with right hand and throttle handle with left hand.

Always stop the engine before removing branches or debris from the cutters! Never allow the cutters to contact buildings or other hard objects!

Never operate this unit if the safety guard has been removed or damaged!

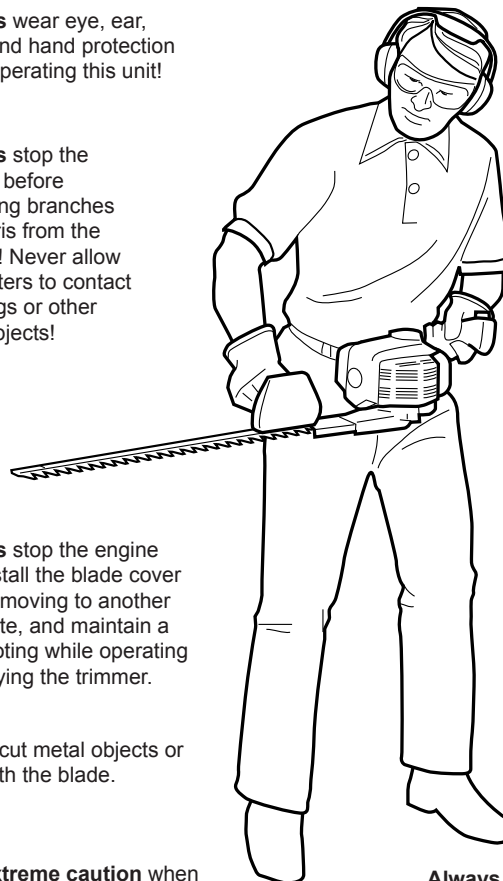

Always stop the engine and install the blade cover before moving to another work site, and maintain a firm footing while operating or carrying the trimmer.

Avoid using or storing this unit in a wet environment. Water on the cutters may enter the gearcase and damage your unit.

Never cut metal objects or wire with the blade.

Avoid cutting large or extremely "woody" branches. Doing so can shorten cutter life, and may also damage the gearcase.

Use extreme caution when operating near fences or electric wiring.

Always keep proper footing and do not overreach. Maintain your balance at all times during operation.

Figure 1



WARNING!

The ignition components of this machine generate an electromagnetic field during operation which may interfere with some pacemakers. To reduce the risk of serious or fatal injury, persons with pacemakers should consult with their physician and the pacemaker manufacturer before operating this machine. In the absence of such information, ECHO does not recommend the use of Shindaiwa products by anyone who has a pacemaker.

Operating Precautions

- Never transport the hedge trimmer or leave it unattended with the engine running. An engine that's running could be accidentally accelerated causing the blades to oscillate.
- Make sure that the blade cover is in place when transporting or storing the hedge trimmer.
- Always make sure that the cutter attachment and all handles and guards are properly installed and firmly tightened before operation.
- Inspect for broken, missing or improperly installed parts or attachments.
- Never use a cracked or warped cutter or cutter bar: replace it with a serviceable one and make sure it fits properly.
- Make sure there are no missing or loose fasteners, and that the stop switch and throttle controls are working properly.
- Make sure there is always good ventilation when operating the hedge trimmer. Fumes from engine exhaust can cause serious injury or death. Never run the engine indoors!



WARNING!

- Never smoke or light fires near the hedge trimmer. Keep the unit away from excessive heat. Engine fuel is very flammable and fire could lead to serious personal injury or property damage.
- Make sure the cutters are correctly adjusted before operating the hedge trimmer (see the section "Blades" for cutter adjustment procedures). Never attempt cutter adjustment with the engine running!
- Before starting the engine, make sure the cutter is not contacting anything.
- Always confirm safe operation when using the machine.
- Immediately stop the engine with the stop switch if the machine suddenly begins to vibrate or shake.
- Always stop the engine immediately and check for damage if you strike a foreign object or if the machine becomes tangled. Do not operate with broken or damaged equipment.
- When cutting a branch that is under tension, be alert for spring-back so that you will not be struck by the moving branch.
- If a cutter should bind fast in a cut, shut off the engine immediately. Push the branch or tree to ease the bind and free the cutter.
- Always stop the engine and allow it to cool before refueling. Avoid overfilling and wipe off any fuel that may have spilled.
- To reduce fire hazard, keep the engine and muffler free of debris, leaves, or excessive grease
- Keep a Solid Stance. Maintain footing and balance at all times. Do not stand on slippery, uneven or unstable surfaces. Do not work in odd positions or on ladders. Do not over reach.



WARNING!

Hedge Trimmer blades are very sharp. Touching them may lead to severe personal injury. Avoid touching blades whenever possible, and always wear gloves to protect hands

CAUTION!

- Always maintain the hedge trimmer according to this owner's manual and follow the recommended scheduled maintenance.
- Never modify or disable any of the hedge trimmer's safety devices. Doing so may cause damage and lead to personal injury
- Always use genuine Shindaiwa parts and accessories when repairing or maintaining this machine.
- Do not make unauthorized modifications to the hedge trimmer or its components.
- Keep the cutters sharp and properly adjusted.
- Never allow the engine to run at high without a load. Doing so could damage the engine.
- When transporting the hedge trimmer in a vehicle, tie it down securely to prevent fuel spillage or damage to the machine.
- Always stop the engine and allow it to cool before refueling. Avoid overfilling and wipe off any fuel that may have spilled.
- Never place flammable material close to the engine muffler and never run the engine without the spark arrestor screen in place.
- Always clear your work area of trash or hidden debris to help ensure good footing.
- Keep the hedge trimmer as clean as possible. Keep it free of loose vegetation, mud, etc.



WARNING!

Inspect support and throttle handles for damaged or loose attachments before use. NEVER operate a hedge trimmer with damaged or loose handles.

Safety Equipment and Labels

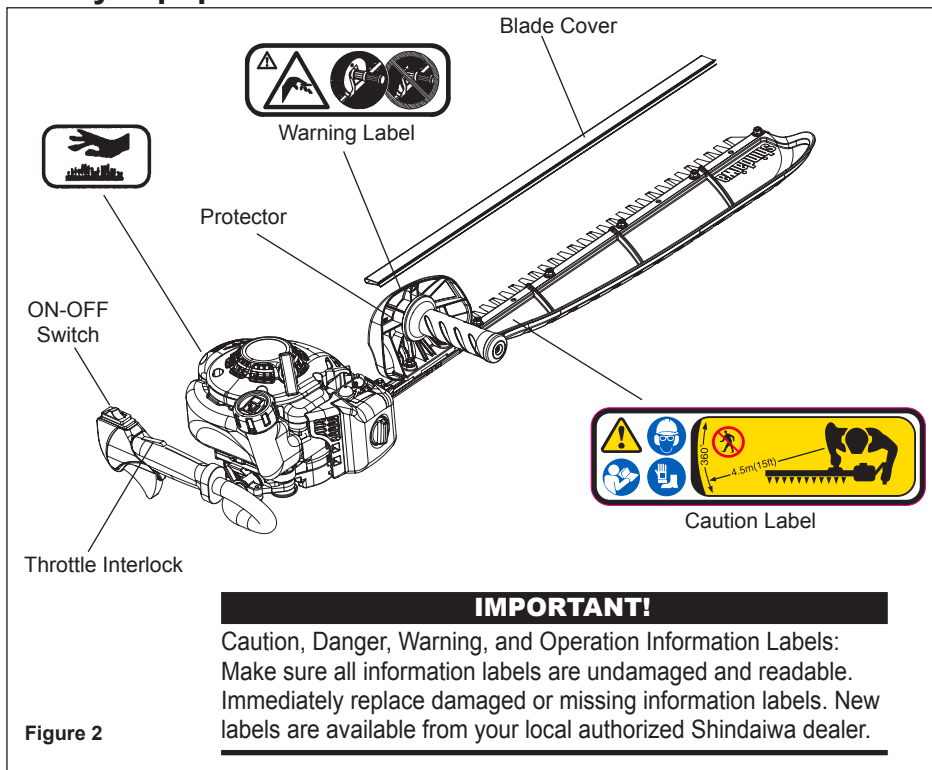

Figure 2

Specifications

Model	HT235
Engine Type	2-cycle, horizontal cylinder, air cooled
Engine Bore x Stroke	32.2mm x 26mm (1.27 x 1.02 in)
Engine Displacement	21.2cc (1.29 in ³)
Unit Weight, Less Fuel	4.88 kg (10.8 lb)
Unit Dimensions (LxWxH)	1300 x 258 x 195 mm (51.2 x 10.2 x 7.7 in)
Fuel Tank Capacity	0.37 liter/ 12.5 oz.
Fuel/oil ratio	50:1 Shindaiwa Red Armor® ISO-L-EGD (ISO/CD 13738) and J.A.S.O. M345- FD, two-stroke, air-cooled engine oil.
Carburetor	Diaphragm type
Ignition	Fully electronic, CDI controlled
Spark Plug	NGK BPMR8Y
<i>Electrode Gap</i>	0.6 mm/ 0.024 in.
<i>Torque</i>	16.7 - 18.6 N·m / 148-165 in • lbf
Air Cleaner	Dry element
Muffler Type	Spark arrestor muffler or spark arrestor muffler with catalyst
Starting Method	Recoil type
Stopping Method	Slide switch, grounding type
Blade Length	955 mm (37.5 in)
Cutting Length	834 mm (32.8 in)
Blade Type	Double-blade cutting action: single edged blade
Clutch Type	Centrifugal clutch, dry-type
Gear Type	Spur gears
Gear Lubrication	Lithium-based grease
Standard Equipment	Throttle handle with integral controls, anti-vibe mountings, support handle with guard, spark plug wrench and blade cover
Engine Speed	3,300 RPM
Clutch Engagement Speed	4,700 RPM
Wide Open Throttle Speed (W.O.T.)	10,850 RPM

IMPORTANT!

This spark ignition system complies with the Canadian standard ICES-002.

Specifications are subject to change without notice.

CARB And EPA Emissions Control Information

The emission control system for the engine is EM (engine modification) and, if the second to last character of the Engine Family on the Emission Control Information label (sample below) is “B”, “C”, “K”, or “T”, the emission control system is EM and TWC (3-way catalyst). The fuel tank/fuel line emission control system is EVAP (evaporative emissions). Evaporative emissions for California models are only applicable to fuel tanks and fuel feed lines.



An Emission Control Label is located on the engine. (This is an EXAMPLE ONLY; information on label varies by engine FAMILY).

PRODUCT EMISSION DURABILITY (EMISSION COMPLIANCE PERIOD)

The 50 or 300 hour emission compliance period is the time span selected by the manufacturer certifying the engine emissions output meets applicable emissions regulations, provided that approved maintenance procedures are followed as listed in the Maintenance Section of this manual.

Unit Description

Familiarize yourself with your machine and its various components. Understanding your machine helps ensure top performance, long service life, and safer operation.

Prior to use

Before using this product, please make sure you have all the components required for a complete unit:

- Engine assembly and gearcase/cutter assembly
- Blade Cover
- Operator's Manual
- Emission Control Warranty Statement

Carefully inspect all components for damage.



WARNING!

Do not make unauthorized modifications or alterations to this machine or any of its components or accessories.

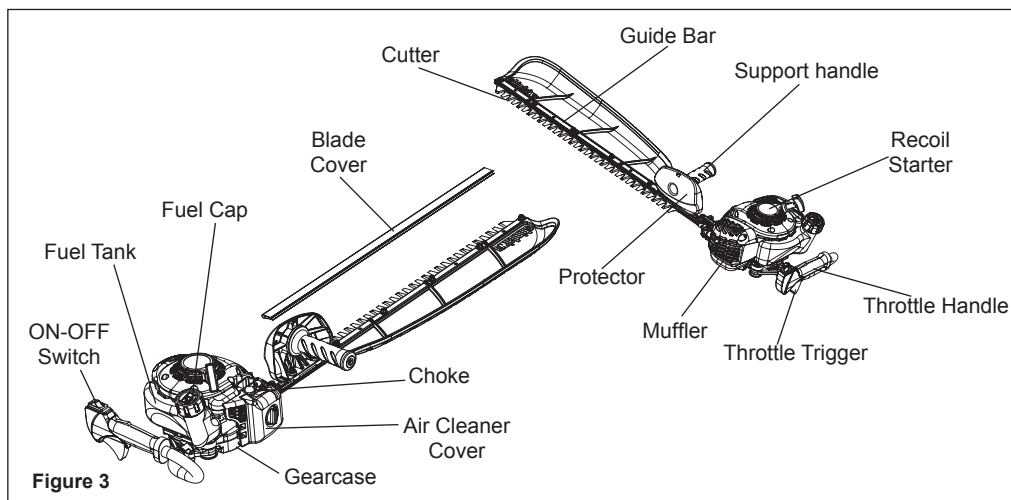

Mixing Fuel



WARNING!

Alternative fuels, such as E15 (15% ethanol), E-85 (85% ethanol) or any fuels not meeting Shindaiwa requirements are **NOT** approved for use in Shindaiwa gasoline engines. Use of alternative fuels may cause performance problems, loss of power, overheating, fuel vapor lock, and unintended machine operation, including, but not limited to, improper clutch engagement. Alternative fuels may also cause premature deterioration of fuel lines, gaskets, carburetors and other engine components.

Fuel Requirements

Gasoline - Use 89 Octane [R+M/2] (mid grade or higher) gasoline known to be good quality. Gasoline may contain up to 10% Ethanol (grain alcohol) or 15% MTBE (methyl tertiary-butyl ether). Gasoline containing methanol (wood alcohol) is NOT approved. ECHO brand Power Fuel™ is 93 octane, ethanol-free fuel premixed with ECHO Red Armor® engine oil at 50:1 ratio. Use of ECHO Power Fuel™ is recommended to extend engine life in all air-cooled 2-stroke and 2/4-stroke hybrid engines.

2 Stroke Mixture Oil - A 2-stroke engine oil meeting ISO-L-EGD (ISO/CD 13738) and J.A.S.O. M345/FD standards must be used. Shindaiwa Red Armor™ 2-Stroke Oil is strongly recommended as it meets this standard and is specifically formulated for use in all Shindaiwa 2-stroke engines. Engine problems due to inadequate lubrication caused by failure to use an ISO-L-EGD (ISO/CD 13738) and J.A.S.O. M345/FD certified oil will void the engine warranty.

IMPORTANT!

Shindaiwa Red Armor™ 2-Stroke oil engine oil may be mixed at 50:1 ratio for application in all Shindaiwa engines sold in the past, regardless of ratio specified in those manuals.

IMPORTANT!

Stored fuel ages. Do not mix more fuel than you expect to use in thirty (30) days, ninety (90) days when a fuel stabilizer is added. Use of unmixed, improperly mixed, or stale fuel, may cause hard starting, poor performance, or severe engine damage and void the product warranty. Read and follow instructions in the Long Term Storage section of this manual.

Examples of 50:1 mixing quantities

Fuel to Oil Mix - 50:1 Ratio			
US		Metric	
Gas	Oil	Gas	Oil
Gallons	Oz.	Liter	CC.
1	2.6	5	100
2	5.2	10	200
5	13	25	500

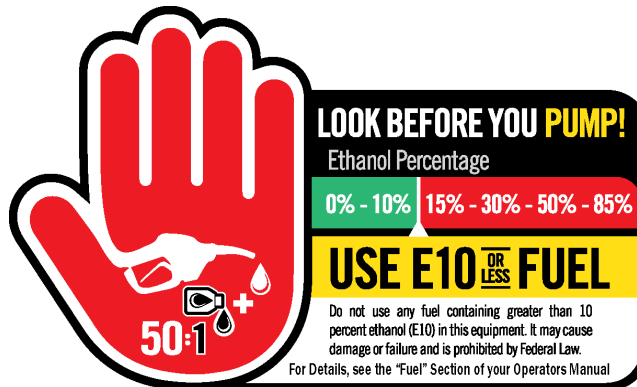

Handling Fuel



DANGER

Fuel is VERY flammable. Use extreme care when mixing, storing or handling or serious personal injury may result.

- Use an approved fuel container.
- DO NOT smoke near fuel.
- DO NOT allow flames or sparks near fuel.
- Fuel tanks/cans may be under pressure. Always loosen fuel caps slowly allowing pressure to equalize.
- NEVER refuel a unit when the engine is HOT or RUNNING!
- DO NOT fill fuel tanks indoors. ALWAYS fill fuel tanks outdoors over bare ground.
- DO NOT overfill fuel tank. Wipe up spills immediately.
- Securely tighten fuel tank cap and close fuel container after refueling.
- Inspect for fuel leakage. If fuel leakage is found, do not start or operate unit until leakage is repaired.
- Move at least 3m (10 ft.) from refueling location before starting the engine.

Mixing Instructions

1. Fill an approved fuel container with half of the required amount of gasoline.
2. Add the proper amount of engine oil to gasoline.
3. Close container and shake to mix oil with gasoline.
4. Add remaining gasoline, close fuel container, and remix.

IMPORTANT!

Spilled fuel is a leading cause of hydrocarbon emissions. Some states may require the use of automatic fuel shut-off containers to reduce fuel spillage.

After use

- DO NOT store a unit with fuel in its tank. Leaks can occur. Return unused fuel to an approved fuel storage container.

Storage - Fuel storage laws vary by locality. Contact your local government for the laws affecting your area. As a precaution, store fuel in an approved, airtight container. Store in a well-ventilated, unoccupied building, away from sparks and flames.

IMPORTANT!

Stored fuel may separate. ALWAYS shake fuel container thoroughly before each use.

Filling the Fuel Tank



WARNING!

Minimize the Risk of Fire

- **NEVER** smoke or light fires near the engine.
 - **ALWAYS** stop the engine and allow it to cool before refueling.
 - **ALWAYS** Wipe all spilled fuel and move at least 3 meters (10 feet) from the fueling point and source before starting.
 - **NEVER** place flammable material close to the engine muffler.
 - **NEVER** operate the engine without the muffler and spark arrester screen in place and in good working condition.
- **FUEL IS HIGHLY FLAMMABLE.**
 - **ALWAYS** store gasoline in a container approved for flammable liquids.
 - **ALWAYS** inspect the unit for fuel leaks before each use. During each refill, check that no fuel leaks from around the fuel cap and/or fuel tank. If fuel leaks are evident, stop using the unit immediately. Fuel leaks must be repaired before using the unit.
 - **ALWAYS** move the unit at least 3 meters (10 feet) away from a fuel storage area or other readily flammable materials before starting the engine.

1. Place the unit on a flat, level surface.
2. Clear any dirt or other debris from around the fuel filler cap.

CAUTION!

Slowly remove the fuel cap only after stopping the engine

3. Remove the fuel cap, and fill the tank with clean, fresh fuel.
4. Reinstall the fuel filler cap and tighten firmly.
5. Wipe away any spilled fuel before starting engine.

Starting Procedure

IMPORTANT!

Engine ignition is controlled by a two-position on-off switch mounted on the throttle body. This switch is typically labeled "I" for ON and "O" for OFF.



WARNING!

The attachment will operate immediately when the engine starts and could result in loss of control and possible serious injury. Keep movable parts of the attachment away from objects that could become entangled or thrown.



WARNING!

Never start the engine from the operating position. The cutting attachment will move when the engine accelerates!

NOTE:

The blade cover is used for transportation and storage. Remove blade cover before using the unit.

1. Move the ignition stop switch to the rear (towards the grip) to the "I" or ON position. See Figure 4.

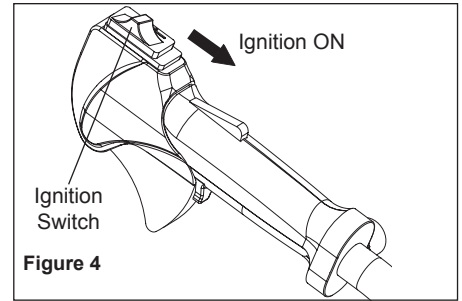

2. Prime the carburetor by repeatedly depressing the carburetor primer bulb until clear fuel can be seen flowing through the transparent primer bulb.

IMPORTANT!

The primer system only pushes fuel through the carburetor. Repeatedly pressing the primer bulb will not flood the engine with fuel.

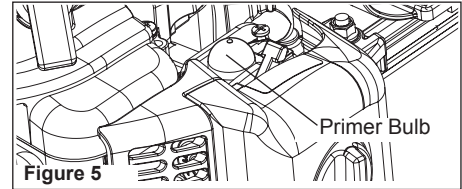

3. (Cold engine only) Choke the engine by moving the choke lever *backward* to the "closed" position. See Figure 6.

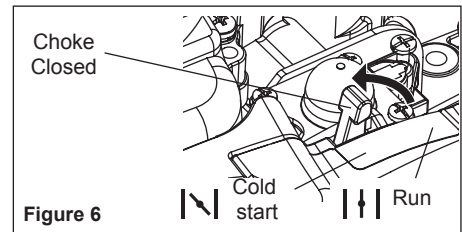

Cranking the Engine

1. Place the unit on the ground. Grip the support handle with your right hand and the starter handle with your left hand (shown).
2. After engine fires, move choke to the RUN (OPEN) position and restart engine if necessary.

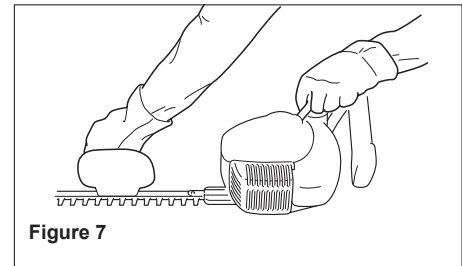

CAUTION!

The recoil starter can be easily damaged by abuse!

- Always engage the starter before attempting to crank the engine.
- Never pull the starter cord to its full length.
- Always rewind the starter cord slowly.

When the motor starts...

1. Allow unit to warm up at idle for several minutes.

If the engine does not start

- Repeat the appropriate starting procedure for a cold or warm engine.
- If the engine still fails to start, use the procedures for "Starting a flooded engine."

WARNING!

The cutting attachment will move when the engine accelerates!

Operation



WARNING!

Moving parts can amputate fingers or cause severe injuries. Keep hands, clothing and loose objects away from all openings. Always stop engine, disconnect spark plug, and make sure all moving parts have come to a complete stop before removing obstructions, clearing debris, or servicing unit.



WARNING!

Engine exhaust IS HOT, and contains Carbon Monoxide (CO), a poison gas. Breathing CO can cause unconsciousness, serious injury, or death. Exhaust can cause serious burns. ALWAYS position unit so that exhaust is directed away from your face and body.



WARNING!

Operation of this equipment may create sparks that can start fires. This unit is equipped with a spark arrestor to prevent discharge of hot particles from the engine. Metal blade use also can create sparks if the blade strikes rocks, metal, or other hard objects. Contact local fire authorities for laws or regulations regarding fire prevention requirements.

- Squeezing the throttle increases engine speed, causing the clutch to engage and operate the cutters.
- Releasing the throttle decreases engine speed, causing the cutters to slow, and then stop altogether as the clutch disengages.
- Use a sweeping motion when cutting, and vary throttle settings often.
- Avoid cutting material larger than .5 in (1.3 cm) in diameter.

Starting a Flooded Engine

Starting A Flooded Engine

1. Slide the ignition switch to the "I" (ON) position.
2. Open the choke, put the throttle lever in the full throttle position, then clear excess fuel from the combustion chamber by cranking the engine several times.
3. If the engine still fails to start or fire, refer to the troubleshooting flow chart at the end of this manual.

Stopping the Engine

1. Cool the engine by allowing it to idle for 2–3 minutes.
2. Move the ignition switch to the "O" or STOP position. See Figure 8.



WARNING!

If engine does not stop when stop switch is moved to STOP position, close choke - COLD START position - to stall engine. Have your Shindaiwa dealer repair stop switch before using hedge trimmer again.

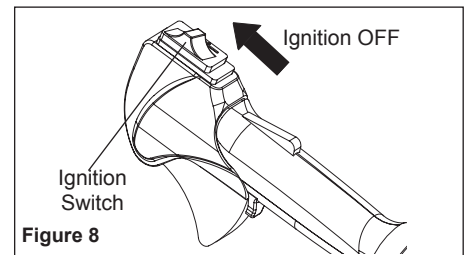

Maintenance and Adjustments

IMPORTANT!

Maintenance, replacement or repair of emission control devices and systems may be performed by any repair establishment or individual; however, warranty repairs must be performed by a dealer or service center authorized by ECHO, Inc. The use of parts that are not equivalent in performance and durability to authorized parts may impair the effectiveness of the emission control system and may have a bearing on the outcome of a warranty claim.

NOTE:

Using non-standard replacement parts could invalidate your Shindaiwa warranty.



WARNING!

Before performing any maintenance, repair, or cleaning work on the unit, make sure the engine and cutting attachment are completely stopped. Disconnect the spark plug wire before performing service or maintenance.



WARNING!

Non-standard accessories, cutting attachment, or replacement parts may not operate properly with your unit and may cause damage and lead to personal injury.

Muffler

This unit must never be operated with a faulty or missing spark arrester or muffler. Make sure the muffler is well secured and in good condition. A worn or damaged muffler is a fire hazard and may also cause hearing loss.

Spark Plug

Keep the spark plug and wire connections tight and clean.

Fasteners

Make sure nuts, bolts, and screws (except carburetor adjusting screws) are tight.

Daily Maintenance/Inspection

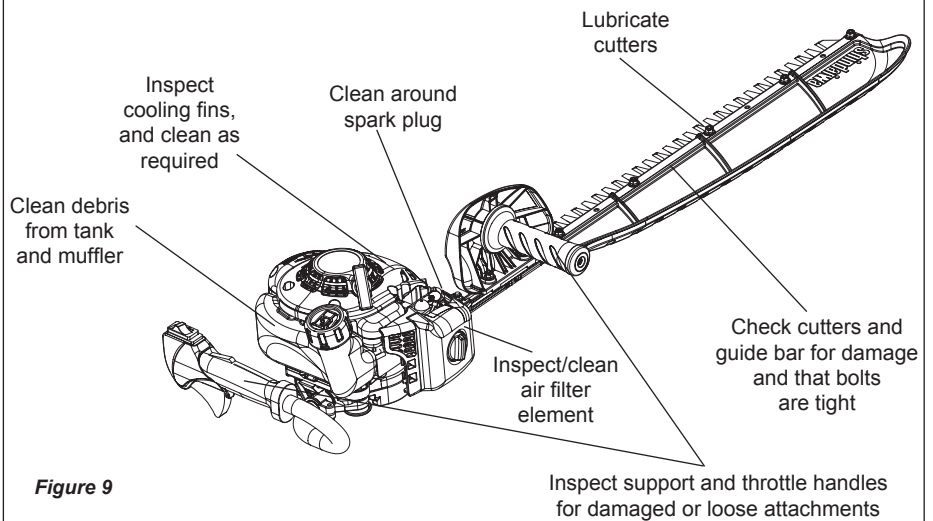

Daily Maintenance/Inspection

1. Remove all grass clippings and dirt from the hedge trimmer.
 - Remove any compacted debris from around the fuel tank and/or muffler.
 - Inspect the engine cooling fins for clogging, and clean as necessary.
 - Clean under the cylinder cover and around the spark plug.
 - Inspect the air filter element for clogging, clean as necessary.
2. Check for loose, damaged, or missing components, and repair as necessary.
3. Lubricate the cutters with oil before use, and after refueling.
4. Check the cutters for damage and make sure all bolts are tight.



WARNING!

To reduce fire hazard, keep the engine and muffler free of debris, leaves, or excessive grease.

Assembly and Adjustments

Throttle Cable Free Play

If the unit does not return to idle speed or doesn't reach full rpm, the throttle lever free play may need to be adjusted as follows:

1. Measure free play at the end of the throttle lever. Throttle lever free play should be approximately. See Figure 10.
2. If adjustment is necessary, remove the air cleaner cover by loosening the cleaner cover knob.
3. Turn the cable locknut fitting in or out until throttle lever free play is approximately.
4. Replace the air cleaner cover, and tighten the cover retaining screws securely.

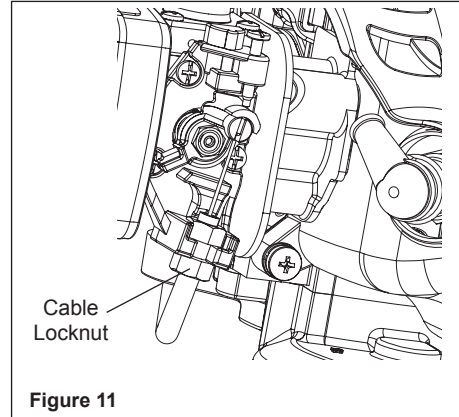
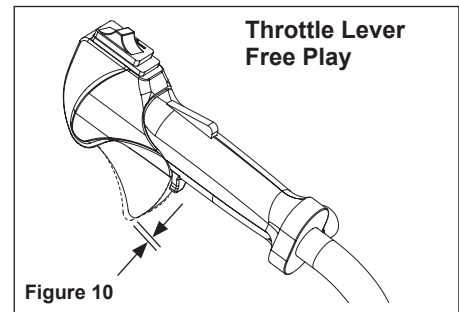

10-Hour Maintenance

(more frequently in dusty conditions)

1. Close choke. Remove the air cleaner cover by loosening the cleaner cover knob. See Figure 12.
2. Inspect the air cleaner element. If the element is damaged or distorted, replace it with a new one.
3. Tap filter gently on a hard surface to dislodge debris from element or use compressed air from the inside to blow debris out and away from the air filter element.

IMPORTANT!

Direct the air stream at the inside face of the filter only!

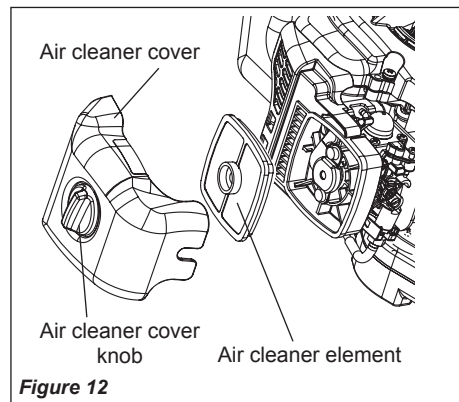

4. Install the filter element and cover in the reverse order of removal.

CAUTION!

Never operate the unit if the air cleaner assembly is damaged or missing!

10/15-Hour Maintenance

Every 10 to 15 hours of operation:

- Remove and clean the spark plug.
Adjust the spark plug electrode gap to 0.6 mm (0.024 in). If the spark plug must be replaced, use only an NGK BPM8Y or equivalent spark plug of the correct heat range. See Figure 13.

CAUTION!

Before removing the spark plug, clean the area around the plug to prevent dirt and debris from getting into the engine's internal parts.

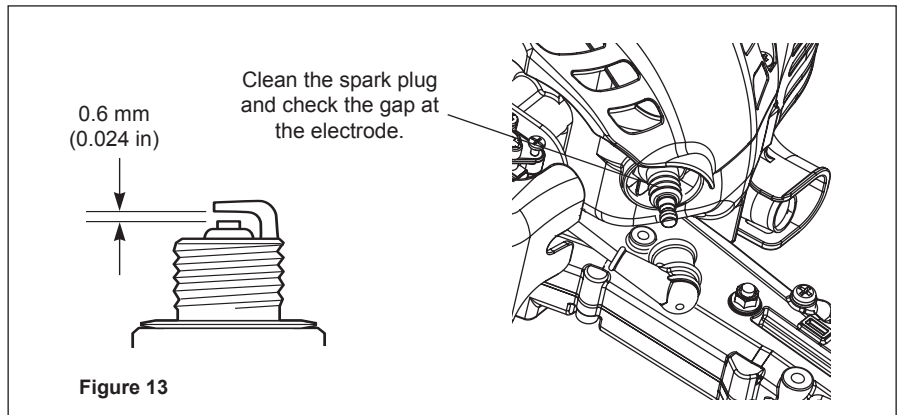

Every 20 Hours

Gearcase Lubrication

1. Clean dirt from grease fitting (A) and grommet (B).
2. Do not force grease. Too much pressure will force grease past seals and cause damage. Apply 1-2 pumps of grease every 20 hours of operation.
3. Remove the grommet next to the grease icon then add grease as illustrated.
4. Reinstall the grommet securely in the hole otherwise, it may become lost.

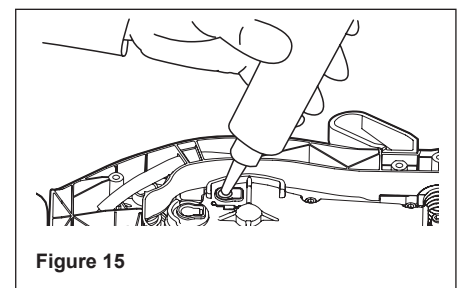
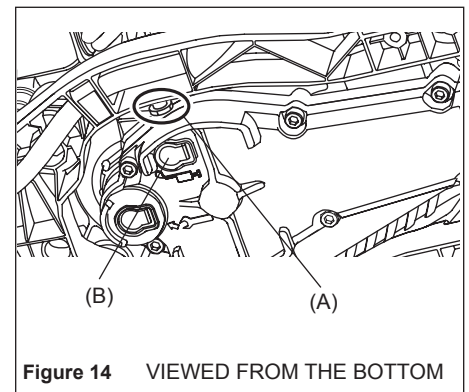

Blades

Lubrication

1. Apply a few drops of oil the each bolt slots at the bottom of blades.

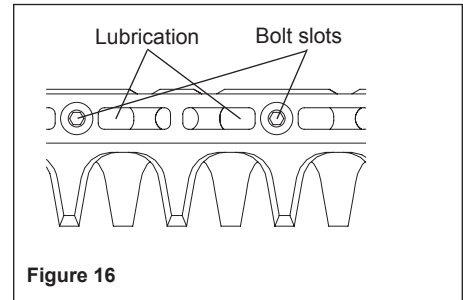

Sharpening blade

1. Slide blades to allow file clearance using slots on bottom of blades. Do not pry against cutting edges.
2. Follow the original shape and file each cutting edge carefully to avoid damage to adjacent teeth.
(A) 10mm Radius (B):100°(aprox) (C):35° (D):45°
3. Lubricate blades.

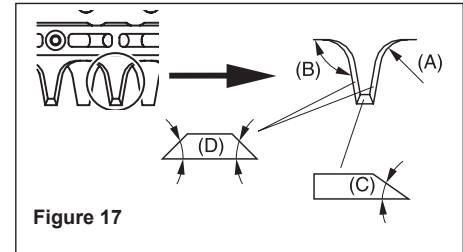

NOTE:

If the cutting blades overlap one another and are difficult to sharpen, move them as explained below.

1. Remove the grommet next to the tool icon on bottom of gear case.
2. Install a 5x10 mm screw in the gear shaft threads. Move blades by turning the screw with a wrench.
3. Reinstall the grommet securely in the hole otherwise, it may become lost.

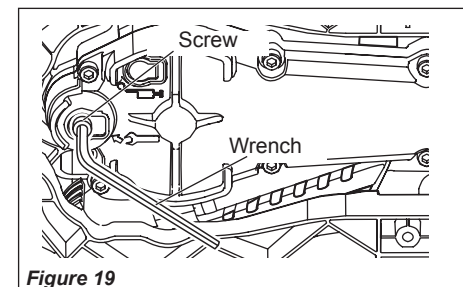
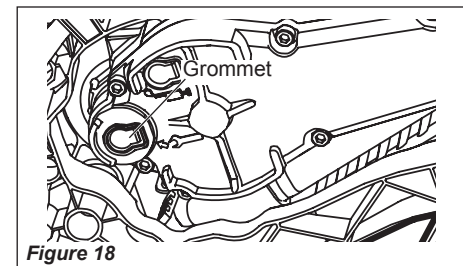

50-Hour Maintenance

Every 50 hours of operation (more often in dusty or extreme conditions)

- Remove and clean the cylinder cover and clean grass and dirt from the cylinder fins.
1. Remove the 2 muffler cover screws and the muffler cover.
 2. Remove the 5 cylinder cover screws and the cylinder cover. See Figure 20.
 3. Clean grass and dirt from the cylinder fins.

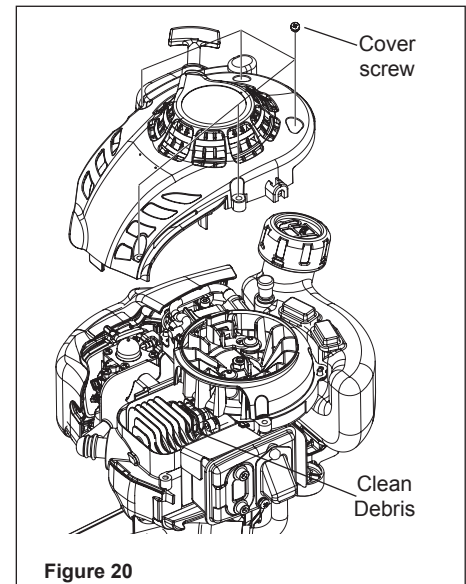

- Extract the fuel filter from inside the fuel tank. (Figure 21). Inspect the fuel filter element. If it shows signs of contamination from debris, replace it with a genuine Shindaiwa replacement fuel filter element. Before reinstalling the filter, inspect the fuel line. If you discover damage or deterioration, the unit should be removed from service until it can be inspected by a Shindaiwa-trained service technician.

CAUTION!

Make sure you do not pierce the fuel line with the end of the hooked wire. The line is delicate and can be damaged easily.

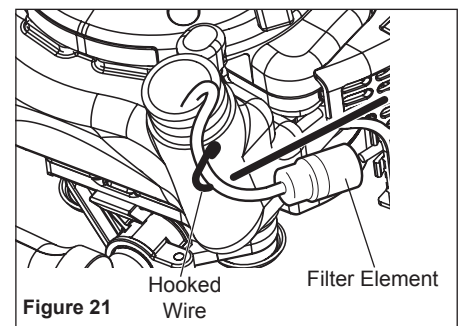

NOTE:

Federal EPA regulations require all model year 2012 and later gasoline powered engines produced for sale in the United States to be equipped with a special low permeation fuel supply hose between the carburetor and fuel tank. When servicing model year 2012 and later equipment, only fuel supply hoses certified by EPA can be used to replace the original equipment supply hose. Fines up to \$37,500 may be enforced for using an un-certified replacement part.)

135-Hour or Annual Maintenance

- Replace the spark plug annually: Use only NGK BPM8Y or equivalent spark plug of the correct heat range. Set spark plug electrode gap to 0.6 mm.

CAUTION!

- If you are unfamiliar with this engine or uncomfortable with this procedure, Consult with an authorized Shindaiwa servicing dealer.

Spark Arrester Screen Maintenance

If the engine becomes sluggish and low on power, check and clean the spark arrester screen.



WARNING!

Never operate the unit with a damaged or missing muffler or spark arrester! Operating with a missing or damaged spark arrester is a fire hazard and could also damage your hearing.

1. Remove the 2 muffler cover screws and the muffler cover. See Figure 22.
2. Remove the 3 screws holding the spark arrester screen, gasket and cover to the muffler. See Figure 22.
3. Remove the 2 muffler screws and the muffler. See Figure 22.
4. Remove the spark arrester screen and clean it with a stiff bristle brush.

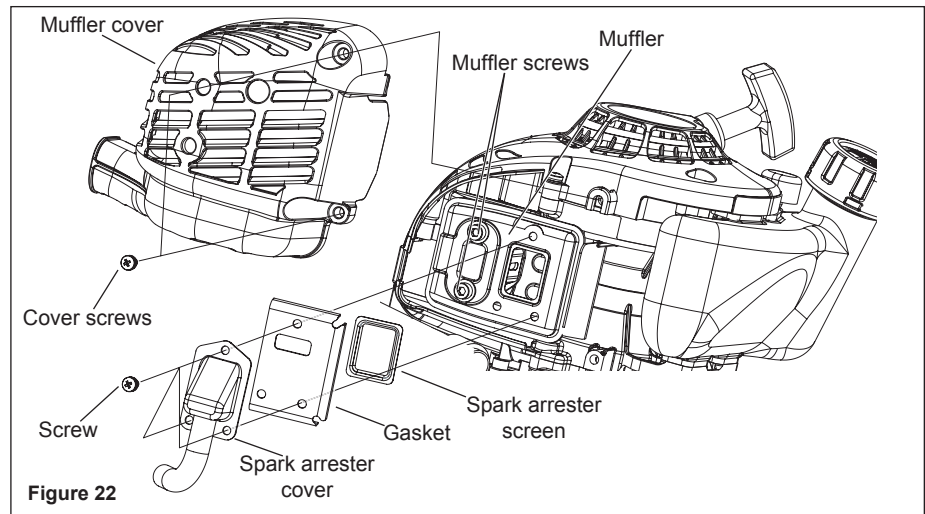

5. Inspect the cylinder exhaust port for any carbon buildup.
6. Reassemble the spark arrester, muffler and muffler cover in the reverse order of disassembly.

IMPORTANT!

If you note excessive carbon buildup, consult with an authorized Shindaiwa servicing dealer.

Carburetor Adjustment

Engine Break-In

New engines must be operated a minimum duration of two tanks of fuel break-in before carburetor adjustments can be made. During the break-in period your engine performance will increase and exhaust emissions will stabilize. Idle speed can be adjusted as required.

High Altitude Operation

This engine has been factory adjusted to maintain satisfactory starting, emission, and durability performance up to 1,100 feet above sea level (ASL) (96.0 kPa). To maintain proper engine operation and emission compliance above 1,100 feet ASL the carburetor may need to be adjusted by an authorized Shindaiwa service dealer.

IMPORTANT!

If the engine is adjusted for operation *above* 1,100 feet ASL, the carburetor must be re-adjusted when operating the engine *below* 1,100 feet ASL, otherwise severe engine damage may result.

NOTE:

Every unit is run at the factory and the carburetor is set in compliance with emission regulations. Carburetor adjustments, other than idle speed, must be performed by an authorized Shindaiwa dealer.

Adjusting Engine Idle

The engine **must** return to idle speed whenever the throttle lever is released. Idle speed is adjustable, and **must** be set low enough to permit the engine clutch to disengage the cutters.

Idle Speed Adjustment

1. Start the engine, and then allow it to idle 2–3 minutes until warm.
2. If the cutters move when the engine is at idle, reduce idle speed by turning the idle adjustment screw (A) counterclockwise.
3. If a tachometer is available, adjust idle. Check Specifications page for correct idle speed
4. Carburetor fuel mixture adjustments are preset at the factory and cannot be adjusted or serviced in the field.

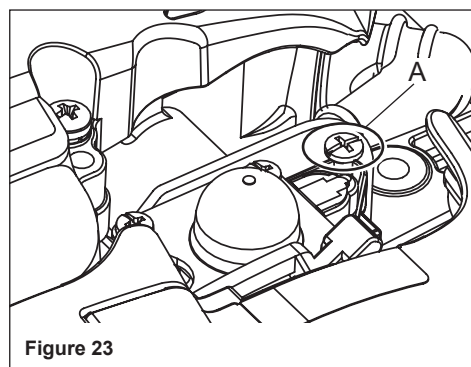

Figure 23



WARNING!

The cutters must NEVER engage at engine idle speeds! If the idle speed cannot be adjusted by the above procedure, return the trimmer to your Shindaiwa dealer for inspection.

Long Term Storage

Whenever the unit will not be used for 30 days or longer, use the following procedures to prepare it for storage:

- Clean external parts thoroughly and apply a light coating of oil to all metal surfaces.
- Drain all the fuel from the carburetor and the fuel tank.

To do so:

1. Prime the primer bulb until no more fuel is passing through.
2. Start and run the engine until it stops running.
3. Repeat steps 1 and 2 until the engine will no longer start.

CAUTION!

Gasoline stored in the carburetor for extended periods can cause hard starting, and could also lead to increased service and maintenance costs.

IMPORTANT!

All stored fuels should be stabilized with a fuel stabilizer such as STA-BIL™.

NOTE:

Damage resulting from stale or contaminated fuel is not covered by the Shindaiwa warranty policy.

- Remove the spark plug and pour about 1/4 oz. of engine oil into the cylinder through the spark plug hole. Slowly pull the recoil starter 2 or 3 times so oil will evenly coat the interior of the engine. Reinstall the spark plug.
- Before storing the unit, repair or replace any worn or damaged parts.
- Remove the air cleaner element from the carburetor and clean it thoroughly. Let reassemble the element.
- Store the unit in a clean, dust-free area.

Troubleshooting Guide

ENGINE DOES NOT START OR HARD TO START

What To Check	Possible Cause	Remedy
Vaporlock.	<ul style="list-style-type: none"> Engine hot/heat soaked. Low fuel quality. 	<ul style="list-style-type: none"> Let cool completely and restart. Refill with fresh, clean unleaded gasoline with a pump octane of 89 or higher mixed with a 2 stroke engine oil that meets or exceeds ISO-L-EGD and/or JASO FD classified oils at 50:1 gasoline/oil ratio.

ENGINE DOES NOT START

What To Check	Possible Cause	Remedy
Does the engine crank?	<p>NO</p> <ul style="list-style-type: none"> Faulty recoil starter. Fluid in the crankcase. Internal damage. 	Consult with an authorized shindaiwa servicing dealer.
YES		
Good compression?	<p>NO</p> <ul style="list-style-type: none"> Loose spark plug. Excess wear on cylinder, piston, rings. 	<ul style="list-style-type: none"> Tighten and re-test. Consult with an authorized shindaiwa servicing dealer.
YES		
Does the tank contain fresh fuel of the proper grade?	<p>NO</p> <ul style="list-style-type: none"> Fuel incorrect, stale, or contaminated; mixture incorrect. 	Refill with fresh, clean unleaded gasoline with a pump octane of 89 or higher mixed with a 2 stroke engine oil that meets or exceeds ISO-L-EGD and/or JASO FD classified oils at 50:1 gasoline/oil ratio.
YES		
Is fuel visible and moving in the return line when priming?	<p>NO</p> <ul style="list-style-type: none"> Check for clogged fuel filter and/or vent. Priming pump not functioning properly. 	<ul style="list-style-type: none"> Replace fuel filter or vent as required. Re-start. Consult with an authorized shindaiwa servicing dealer.
YES		
Is there spark at the spark plug wire terminal?	<p>NO</p> <ul style="list-style-type: none"> The ignition switch is in "O" (OFF) position. Shorted ignition ground. Faulty ignition unit. 	<ul style="list-style-type: none"> Move switch to "I" (ON) position and re-start. Consult with an authorized shindaiwa servicing dealer.
YES		
Check the spark plug.	<ul style="list-style-type: none"> If the plug is wet, excess fuel may be in the cylinder. The plug is fouled or improperly gapped. The plug is damaged internally or of the wrong size. 	<ul style="list-style-type: none"> See "Starting a Flooded Engine" Clean and gap the spark plug. Check the Specifications section for the correct plug and gap for your unit. Restart. Replace the spark plug. Check the Specifications section for the correct plug and gap for your unit. Restart.

Troubleshooting Guide (continued)

LOW POWER OUTPUT

What To Check	Possible Cause	Remedy
Is the engine overheating?	Operator is overworking the unit.	Use a lower throttle setting.
	Carburetor mixture is too lean.	Consult with an authorized shindaiwa servicing dealer.
	Improper fuel ratio.	Refill with fresh, clean unleaded gasoline with a pump octane of 89 or higher mixed with a 2 stroke engine oil that meets or exceeds ISO-L-EGD and/or JASO FD classified oils at 50:1 gasoline/oil ratio.
	Fan, fan cover, cylinder fins dirty or damaged.	Clean, repair or replace as necessary.
	Carbon deposits on the piston or in the muffler.	Consult with an authorized shindaiwa servicing dealer.
Engine is rough at all speeds. May also have black smoke and/or unburned fuel at the exhaust.	Clogged air cleaner element.	Service the air cleaner element.
	Loose or damaged spark plug.	Tighten or replace the spark plug. Check the <i>Specifications</i> section for the correct plug and gap for your unit.
	Air leakage or clogged fuel line.	Repair or replace fuel filter and/or fuel line.
	Water in the fuel.	Refill with fresh, clean unleaded gasoline with a pump octane of 89 or higher mixed with a 2 stroke engine oil that meets or exceeds ISO-L-EGD and/or JASO FD classified oils at 50:1 gasoline/oil ratio.
	Piston seizure.	Consult with an authorized shindaiwa servicing dealer.
	Faulty carburetor and/or diaphragm.	
Engine is knocking.	Overheating condition.	Consult with an authorized shindaiwa servicing dealer.
	Improper fuel.	Refill with fresh, clean unleaded gasoline with a pump octane of 89 or higher mixed with a 2 stroke engine oil that meets or exceeds ISO-L-EGD and/or JASO FD classified oils at 50:1 gasoline/oil ratio.
	Carbon deposits in the combustion chamber.	Consult with an authorized shindaiwa servicing dealer.

Troubleshooting Guide (continued)

ADDITIONAL PROBLEMS

Symptom	Possible Cause	Remedy
Poor acceleration.	Clogged air filter.	Clean the air filter.
	Clogged fuel filter.	Replace the fuel filter.
	Lean fuel/air mixture.	Consult with an authorized shindaiwa servicing dealer.
	Idle speed set too low.	Adjust idle. Check <i>Specifications</i> page for correct idle speed.
Engine stops abruptly.	Ignition switch turned off.	Reset the switch and re-start.
	Fuel tank empty.	Refill with fresh, clean unleaded gasoline with a pump octane of 89 or higher mixed with a 2 stroke engine oil that meets or exceeds ISO-L-EGD and/or JASO FD classified oils at 50:1 gasoline/oil ratio.
	Water in the fuel.	
	Clogged fuel filter.	Replace fuel filter.
	Shorted spark plug or loose terminal.	Clean or replace spark plug. Check the <i>Specifications</i> section for the correct plug and gap for your unit. Tighten the terminal.
	Ignition failure.	Replace the ignition unit.
Piston seizure.	Consult with an authorized shindaiwa servicing dealer.	
Engine difficult to shut off.	Ground (stop) wire is disconnected, or switch is defective.	Test and replace as required.
	Overheating due to incorrect spark plug.	Replace the spark plug. Check the <i>Specifications</i> section for the correct plug and gap for your unit. Restart.
	Overheated engine.	Idle engine until cool.
Engine will not idle down.	Idle set too high.	Adjust idle. Check <i>Specifications</i> page for correct idle speed.
	Engine has an air leak.	Consult with an authorized shindaiwa servicing dealer.
Excessive vibration.	Loose attachment holder.	Inspect and re-tighten holders securely.
	Warped or damaged attachment.	Inspect and replace attachment as required.
	Loose gearcase.	Tighten gearcase securely.
	Bent main shaft/worn or damaged bushings.	Inspect and replace as necessary.
Engine overspeeding.	Shaft not installed in powerhead or gearcase.	Inspect and reinstall as required.
	Broken shaft.	Consult with an authorized shindaiwa servicing dealer.
	Damaged gearcase.	

**SHINDAIWA LIMITED WARRANTY STATEMENT FOR
PRODUCT SOLD IN USA AND CANADA BEGINNING 01/01/2015**

ECHO, INC.'S RESPONSIBILITY

ECHO Incorporated's (ECHO, INC.) Limited Warranty, provides to the original purchaser that this Shindaiwa product is free from defects in material and workmanship. Under normal use and maintenance from date of purchase, ECHO, INC. agrees to repair or replace at its discretion, any defective product free of charge at any authorized Shindaiwa servicing dealer within listed below application time periods, limitations and exclusions. **THIS LIMITED WARRANTY IS ONLY APPLICABLE TO SHINDAIWA PRODUCTS SOLD BY AUTHORIZED SHINDAIWA DEALERS. IT IS EXTENDED TO THE ORIGINAL PURCHASER ONLY, AND IS NOT TRANSFERABLE TO SUBSEQUENT OWNERS EXCEPT FOR EMISSION RELATED PARTS.** Repair parts and accessories replaced under this warranty are warranted only for the balance of the original unit or accessory warranty period. Any damage caused by improper installation or improper maintenance is not covered by this warranty. All parts or products replaced under warranty become the property of ECHO, INC. This warranty is separate from the Emission control warranty statement supplied with your new product. Please consult the Emission Control Warranty Statement for details regarding emission related parts. For a list of Authorized Shindaiwa Dealers refer to WWW.SHINDAIWA.COM or call 1-877-886-7783.

OWNER'S RESPONSIBILITY

To ensure trouble free warranty coverage it is important that you register your Shindaiwa equipment on-line at WWW.SHINDAIWA.COM or by filling out the warranty registration card supplied with your unit. Registering your product confirms your warranty coverage and provides a direct link if we find it necessary to contact you.

The owner shall demonstrate reasonable care and use, and follow preventative maintenance, storage, fuel and oil usage as prescribed in the operator's manual. Should a product difficulty occur, you must, at your expense, deliver or ship your Shindaiwa unit to an authorized Shindaiwa servicing dealer for warranty repairs (within the applicable warranty period), and arrange for pick-up or return of your unit after the repairs have been made. For your nearest authorized Shindaiwa servicing dealer, call Shindaiwa's Dealer Referral Center, at 1-877-886-7783 or you can locate a Shindaiwa servicing dealer at WWW.SHINDAIWA.COM. Should you require assistance or have questions concerning Shindaiwa's Warranty Statement, you can contact our Consumer Product Support Department at 1-800-673-1558 or contact us through the web at WWW.SHINDAIWA.COM.

PRODUCT WARRANTY PERIOD

HOMEOWNER APPLICATION

- **5 YEAR WARRANTY** - Units for homeowner, or non-income producing use will be covered by this limited warranty for five (5) years from date of purchase.

EXCEPTIONS:

- For engine powered products, the electronic ignition module, flexible drive cable, and solid drive shaft are warranted for the life* of the product on parts only.
- Cutting attachments such as, but not limited to, bars, chains, sprockets, lines, blades, PowerBroom™, belts, and nylon trimmer heads for homeowner or non-income producing use will be covered for failures due to defects in material or workmanship for a period of 60 days from original product purchase date. Any misuse from contact with concrete, rocks, or other structures is not covered by this warranty.
- Multipurpose Tool Attachments carry the same warranty duration as the units they are designed to fit.

COMMERCIAL APPLICATION

- **1 YEAR WARRANTY** - All Chain Saws for commercial, institutional, agricultural, industrial, or income producing use will be covered by this limited warranty for 1 year from the date of purchase.
- **2 YEAR WARRANTY** - All other units for commercial, institutional, agricultural, industrial, or income producing use will be covered by this limited warranty for two (2) years from the date of purchase.

EXCEPTIONS:

- For engine powered products, the electronic ignition module, flexible drive cables, and solid drive shafts are warranted for the life* of the product on parts only.
- Cutting attachments such as, but not limited to, bars, chains, sprockets, lines, blades, PowerBroom™, belts, and nylon trimmer heads for commercial, institutional, agricultural, industrial, rental, or income producing will be covered for failures due to defects in material or workmanship for a period of 30 days from original product purchase date. Any misuse from contact with concrete, rocks, or other structures is not covered by this warranty.
- Multipurpose Tool Attachments carry the same warranty duration as the units they are designed to fit.

RENTAL APPLICATION - 90 DAYS WARRANTY

- Units for rental use will be covered against defects in material and workmanship for a period of 90 days from the date of purchase.

- * ECHO INC's liability under the "Lifetime" coverage is limited to furnishing parts specified under the **PRODUCT WARRANTY PERIOD** section of this warranty statement for "Life" free of charge for a period of ten (10) years after the date of the complete unit's final production.

PURCHASED REPAIR PARTS AND ACCESSORIES

- 90-day all applications

ATTENTION ENGINE POWERED PRODUCT OWNERS

This Shindaiwa engine powered product is a quality-engineered unit which has been manufactured to exact tolerances to provide superior performance. To help ensure the performance of the unit, it is required to use engine oil which meets the ISO-L-EGD Standard per ISO/CD 13738 and JASO M345/FD Standards. **Shindaiwa Red Armor™** is a premium engine oil specifically formulated to meet ISO-L-EGD (ISO/CD 13738) and JASO M345/FD Standards. The use of engine oils designed for other applications, such as for outboard motors or lawnmowers can result in severe engine damage, and will void your engine limited warranty.

THIS WARRANTY DOES NOT COVER DAMAGE CAUSED BY:

- Lack of lubrication or engine failure, due to the use of engine oils that do not meet the ISO-L-EGD (ISO/CD 13738) and JASO M345/FD Standards. **Shindaiwa Red Armor™** Engine Oil meets the ISO-L-EGD and JASO M345/FD Standard. Emission related parts are covered for 5 years homeowner or 2 years commercial use regardless of two-stroke oil used, per the statement listed in the EPA or California Emission Control Warranty Explanation.
- Damage caused by use of gasohol, containing methanol (wood alcohol), or gasoline containing less than 88 octane. Only use gasoline which contains 88 octane or higher. Gasohol which contains a maximum 10% ethanol (grain alcohol) or 15% MTBE (methyl/tertiary/butyl/ether) is also approved. The prescribed mixing ratio of gasoline to oil is listed on the Shindaiwa oil label and covered in your operator's manual.
- Engine damage caused by use of ether or any starting fluids.
- Damage caused by tampering with engine speed governor or emission components, or running engines above specified and recommended engine speeds as listed in your operator's manual.
- Operation of the unit with improperly maintained/removed cutting shield or removed/damaged air filter.
- Damage caused by dirt, pressure or steam cleaning the unit, salt water, corrosion, rust, varnish, abrasives, and moisture.
- Defects, malfunctions or failures resulting from abuse, misuse, neglect, modifications, alterations, normal wear, improper servicing, or use of unauthorized attachments.
- Incorrect storage procedures, stale fuel, including failure to provide or perform required maintenance services as prescribed in the operator's manual. Preventative maintenance as outlined in the operator's manual is the customer's responsibility.
- Failures due to improper set-up, pre-delivery service or repair service by anyone other than authorized Shindaiwa servicing dealer during the warranty period.
- Certain parts and other items are not warranted, including but not limited to: lubricants, starter cords, and engine tune-ups.
- Use of spark plugs other than those meeting performance and durability requirements of the OEM spark plug listed in the Operator's Manuals.
- Overheating or carbon scoring failures due to restricted, clogged exhaust port or combustion chamber, including damage to spark arrester screen.
- Adjustments after the first (30) thirty days and beyond, such as carburetor adjustment and throttle cable adjustment.
- Damage to gears or gear cases caused by contaminated grease or oil, use of incorrect type or viscosity of lubricants, and/or failure to comply with recommended grease or oil change intervals.
- Damage caused by pump or sprayer running dry, pumping or spraying caustic or flammable materials, or lack of or broken strainers.
- Additional damage to parts or components due to continued use after operational problem or failure occurs. Should operational problem or failure occur, the product should not be used, but delivered as is to an authorized Shindaiwa servicing dealer.

It is a dealer's and/or customer's responsibility to complete and return the warranty registration card supplied with your Shindaiwa product or by visiting WWW.SHINDAIWA.COM. Your receipt of purchase including date, model and serial number must be maintained and presented to an authorized Shindaiwa servicing dealer for warranty service. Proof of purchase rests solely with the customer. Some states do not allow limitations on how long an implied warranty lasts, so the above limitations may not apply to you. Some states do not allow the exclusion or limitation of incidental or consequential damages, so you may also have other specific legal rights which vary from state to state. This limited warranty is given by ECHO Incorporated, 400 Glanwood Rd., Lake Zurich, IL 60047.

DISCLAIMER OF IMPLIED WARRANTIES

This limited warranty is in lieu of all other expressed or implied warranties, including any warranty of FITNESS FOR A PARTICULAR PURPOSE OR USE and any implied warranty of MERCHANTABILITY otherwise applicable to this product. ECHO, INC. and its affiliated companies shall not be liable for any special incidental or consequential damage, including lost profits. There are no warranties extended other than as provided herein. This limited warranty may be modified only by ECHO, INC.

**E7561128488
B15**

Product Registration

Thank you for choosing Shindaiwa Power Equipment

Please go to <http://www.shindaiwa-usa.com> to register your new product on-line. It's FAST and EASY! NOTE: your information will never be sold or misused by ECHO, Inc. Registering your purchase enables us to contact you in the unlikely event of a service update or product recall, and verifies your ownership for warranty consideration.

If you do not have access to the Internet, you can complete the form below and mail to: ECHO Inc., Product Registration, PO Box 1139, Lake Zurich IL 60047

shindaiwa® PRODUCT REGISTRATION CARD : TARJETA DE REGISTRO : CARTE D'ENREGISTREMENT DU PRODUIT

ONLINE OPTION: Register online and save a stamp! You will be alerted of product updates and/or be sent new Shindaiwa product information and special offers. Simply go to: www.shindaiwa-usa.com

OPCIÓN POR INTERNET: Regístrese en la página web y ahorre una estampilla! Le alertarán sobre actualizaciones del producto y/o se le enviara información sobre los nuevos productos Shindaiwa y las ofertas especiales. Simplemente visite: www.shindaiwa-usa.com

OPTION EN LIGNE: Enregistrer en ligne et épargner un timbre! Vous serez informé sur les nouveaux produits Shindaiwa et les mises à jour de produit ainsi que les offres spéciales. Simplement visitez le: www.shindaiwa-usa.com

Please Print : Por Favor Escribe Con Letra De Molde : En Lettre Carré S.V.P.

Confidential: Information provided will not be shared or sold

Purchaser's Name : Nombre del Comprador : Nom de l'acheteur	
Address : Dirección : Adresse	
City : Ciudad : Ville	State : Estado : Zip Code : Código Postal : Code Postal Province
E-Mail Address : Dirección De Correo Electrónico : Courrier Électronique	
Phone Number : Número De Teléfono : Téléphone	Date of Purchase : Fecha de la Compra : Date de l'achat
Where Purchased : Nombre del Almacén donde fue Comprado : Lieu d'achat	
Model Number : Numero del Modelo : No. de modèle	Serial Number : Numero de Serie : No. de série

Primary use of tool: Professional Homeowner Rental Equip.
 Uso primario de la herramienta: Profesional Dueño de casa Alquiler
 Usage principal: Professionnel Residential Location

Do you wish to receive periodic Shindaiwa product information and special offers by e-mail? Yes No

¿Desea usted recibir información periódica y ofertas especiales por correo electrónico sobre el producto Shindaiwa? Yes No
 Souhaitez-vous recevoir périodiquement de l'information sur les produits Shindaiwa et les offres spéciales par courrier électronique ? Oui Non

Did you visit the Shindaiwa website before purchasing your product?
 Yes No

Visitó usted la página web Shindaiwa antes de comprar su producto?
 Si No
 Avez-vous visité le site d'Shindaiwa avant de procurer votre produit?
 Oui Non

What factor(s) most influenced your purchase?

Performance Price Dealer
 Reliability Prior Experience Quality
 Friend/Family Brand Warranty

¿Qué factor(es) influenció más en su compra?

Funcionamiento Precio Distribuidor
 Confiabilidad Experiencia Anterior Calidad
 Amigo/Familia Marca Garantía
 Performance Prix Marchand
 Fiabilidad Expérience Qualité
 Ami/Famille Marque Garantie

Registering your purchase enables us to contact you in the unlikely event of a service update or product recall and verifies your ownership in the event of loss. El registrar su compra nos permite estar en contacto con usted en caso de cualquier evento como el aviso de servicio o la revocación del producto y verificación de propiedad en caso de robo o pérdida. L'enregistrement de votre achat nous permettra de vous contacter dans le cas improbable de modifications des instructions d'entretien ou de rappel du produit et vérifier que vous êtes le propriétaire en cas de vol ou de perte.

1.877.986.7783

www.shindaiwa-usa.com

X7571120102 02-2012

Servicing Information

Parts/Serial Number

Genuine Shindaiwa Parts and Assemblies for your Shindaiwa products are available only from an Authorized Shindaiwa Dealer. When you do need to buy parts **always** have the Model Number, Type and Serial Number of the unit with you. You can find these numbers on the engine. For future reference, write them in the space provided below.

Model No. _____ SN. _____

Service

Service of this product during the warranty period must be performed by an Authorized SHINDAIWA Service Dealer. For the name and address of the Authorized SHINDAIWA Service Dealer nearest you, ask your retailer or call: 1-877-986-7783. Dealer information is also available on WWW.SHINDAIWA-USA.COM. When presenting your unit for Warranty service/repairs, proof of purchase is required.

Consumer Product Support

If you require assistance or have questions concerning the application, operation or maintenance of this product you may call the SHINDAIWA Consumer Product Support Department at 1-877-986-7783 from 8:00 am to 5:00 pm (Central Standard Time) Monday through Friday. Before calling, please know the model and serial number of your unit.

Warranty Registration

To ensure trouble free warranty coverage it is important that you register your SHINDAIWA equipment on-line at WWW.SHINDAIWA-USA.COM or by filling out the product registration sheet included in this manual. Registering your product confirms your warranty coverage and provides a direct link between you and ECHO if we find it necessary to contact you..

Additional or Replacement Manuals

Replacement Operator and Parts Catalogs are available from your SHINDAIWA dealer or at WWW.SHINDAIWA-USA.COM or by contacting the Consumer Product Support Department (1-877-986-7783). Always check WWW.SHINDAIWA-USA.COM for updated information.

shindaiwa[®]

ECHO Incorporated.
400 Oakwood Road
Lake Zurich, IL 60047-1564 U.S.A.
Telephone: 1-877-986-7783
Fax: 1-847-540-8416
www.Shindaiwa.com

Yamabiko Corporation
7-2 Suehirocho 1-Chome, Ohme,
Tokyo, 198-8760, Japan
Phone: 81-428-32-6118
Fax: 81-428-32-6145