

SHINDAIWA OWNER'S/OPERATOR'S MANUAL

CT2510 CULTIVATOR

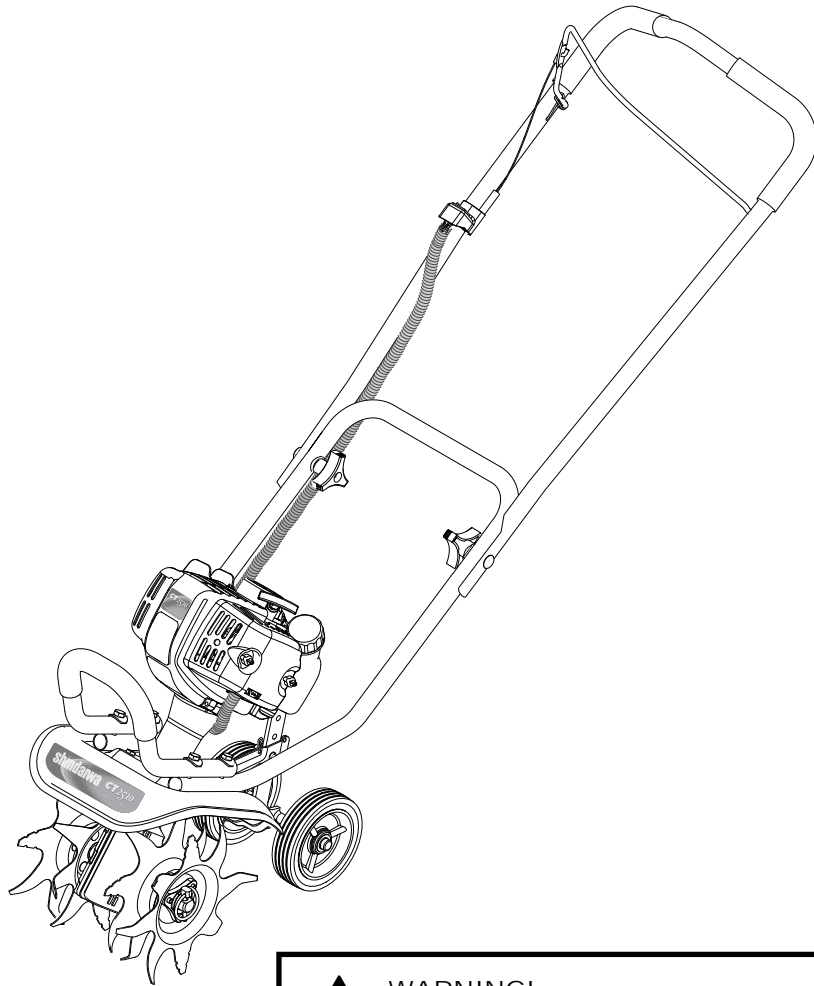

WARNING!

Always wear eye protection when operating this machine. To minimize the risk of injury, read this manual and familiarize yourself with its contents.

shindaiwa®

Part Number 89226 Rev. 12/08

Introduction

The Shindaiwa CT2510 Cultivator has been designed and built to deliver superior performance and reliability without compromise to quality, comfort, safety or durability.

Shindaiwa engines represent the leading edge of high-performance engine technology, delivering exceptionally high power with remarkably low displacement and weight. As an owner/operator, you'll soon discover for yourself why Shindaiwa is simply in a class by itself!

Shindaiwa Inc. reserves the right to make changes to products without prior notice, and without obligation to make alterations to units previously manufactured.

IMPORTANT!

The information contained in these instructions describes units available at the time of publication.



WARNING!
The engine exhaust from this product contains chemicals known to the State of California to cause cancer, birth defects or other reproductive harm.

Contents

	PAGE		PAGE
Operational and warning labels.....	2	Mixing fuel.....	7
Safety	3	Filling the fuel tank	7
Product Description.....	5	Starting the Engine	8
Specifications.....	5	Stopping the Engine	9
Setup and adjustments.....	6	Adjusting Engine Idle	10
		Checking Unit Condition.....	10
		Operation	11
		Maintenance	12
		Troubleshooting Guide	17
		Warranty Statement	20

IMPORTANT!

The operational procedures described in this manual are intended to help you get the most from this unit as well as to protect you and others from harm. These procedures are guidelines for safe operation under most conditions, and are not intended to replace any safety rules and/or laws that may be in force in your area. If you have questions regarding your Shindaiwa hand held power equipment, or if you do not understand something in this manual, contact your local Shindaiwa dealer for assistance. You may also contact Shindaiwa Inc. at the address printed on the back of this Manual.

Attention Statements

Throughout this manual are special "attention statements".



DANGER!
A statement preceded by the triangular attention symbol and the word "DANGER" contains information that should be acted upon to prevent serious injury or death.



WARNING!
A statement preceded by the triangular attention symbol and the word "WARNING" contains information that should be acted upon to prevent serious bodily injury.

IMPORTANT!

A statement preceded by the word "IMPORTANT" is one that possesses special significance.

CAUTION!
A statement preceded by the word "CAUTION" contains information that should be acted upon to prevent mechanical damage.

NOTE:

A statement preceded by the word "NOTE" contains information that is handy to know and may make your job easier.

Operational and warning labels

 <p>This machine operates at very high speeds and has the potential to do serious damage if misused, abused or mishandled. To reduce the risk of injury, you must maintain control at all times.</p>	 <p>Wear non-slip heavy-duty gloves.</p>	 <p>Make sure no one is within 15 M / 50 feet of an operating machine.</p>
 <p>Read and follow this manual, make sure anyone using the trimmer does likewise. Failure to do so could result in serious personal injury or machine failure. Keep this manual for future reference.</p>	 <p>Safety tip shoes or boots with non-slip sole should be worn.</p>	 <p>The tines are sharp! Keep hands away from tines. Rotating tines may cause injury. The tines may continue to rotate after the unit is shut off.</p>
 <p>Always wear eye and hearing protection. Shindaiwa recommends wearing a face shield as additional face and eye protection.</p>	 <p>Beware of thrown or ricocheted objects.</p>	 <p>Keep feet away from tines. Rotating tines may cause injury. The tines may continue to rotate after the unit is shut off.</p>

Safety

Work Safely

This machine operates at very high speeds and has the potential to do serious damage if misused, abused or mishandled. To reduce the risk of injury, you must maintain control at all times, and observe all safety precautions during operation. Never permit a person without training or instruction to operate this machine!

WARNING!
 Never make unauthorized attachment installations. Do not use attachments not approved by Shindaiwa for use on this unit.

WARNING!
 Never operate power equipment of any kind if you are tired or if you are under the influence of alcohol, drugs, medication or any other substance that could affect your ability or judgement.



Stay Alert

You must be physically and mentally fit to operate this unit safely.

WARNING!
 **Use Good Judgement**

NEVER operate this machine around buried electrical cables!

DO NOT operate the tiller/cultivator in standing water.

ALWAYS wear eye protection to shield against thrown objects.

NEVER run the engine when transporting the unit.

NEVER run the engine indoors! Make sure there is always good ventilation. Fumes from engine exhaust can cause serious injury or death.

ALWAYS clear your work area of trash or hidden debris that could tangle in the

tines or be thrown back at you or toward a bystander.

NEVER smoke or light fires near the hedge trimmer. Keep the unit away from excessive heat. Engine fuel is very flammable and fire could lead to serious personal injury or property damage.

ALWAYS stop the engine immediately if it suddenly begins to vibrate or shake. Inspect for broken, missing or improperly installed parts or attachments.

If the tines jam, switch the engine OFF, disconnect the spark plug lead, and inspect the tines, axles, and gearcase for damage.

DO NOT operate this machine with the muffler removed.

ALWAYS keep the unit as clean as practical. Keep it free of loose vegetation, mud, etc.

ALWAYS hold the unit firmly with both hands while operating and maintain control at all times.

ALWAYS keep the handles clean.

ALWAYS disconnect the spark plug wire before performing any maintenance work.

NEVER operate the tiller/cultivator around vines or roots that could tangle in the tines and cause loss of control.

Safety Labels

IMPORTANT!

Safety and Operation Information Labels: Make sure all information labels are undamaged and readable. Immediately replace damaged or missing information labels. New labels are available from your local authorized Shindaiwa dealer.

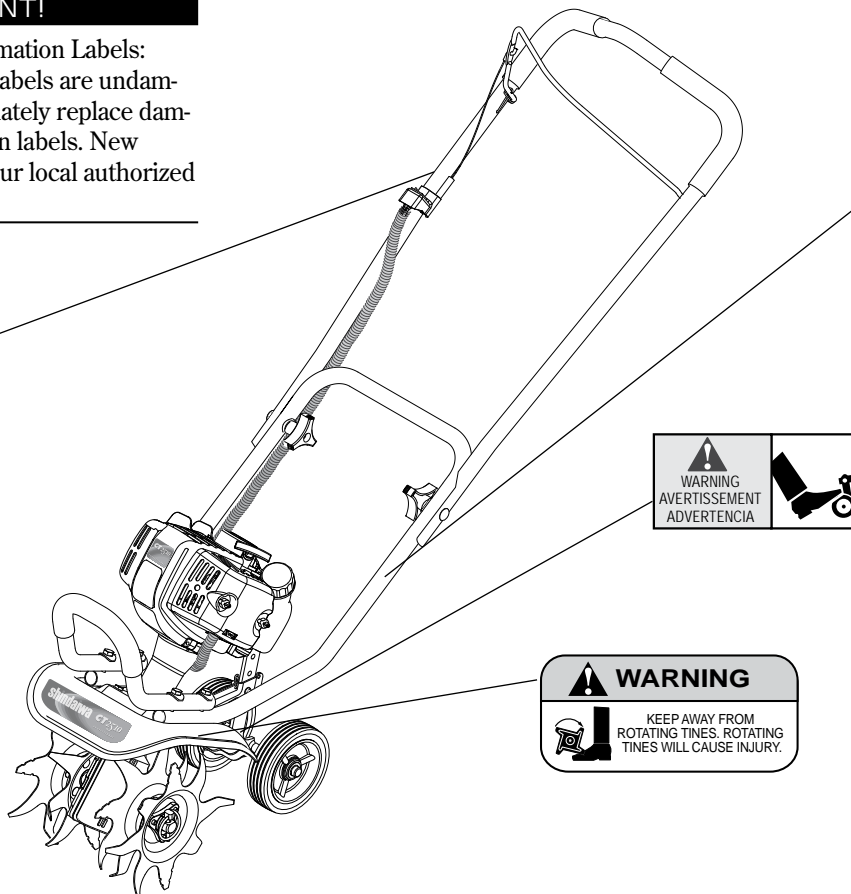
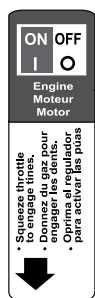

Safety (continued)

The properly equipped operator

Wear nonslip heavy-duty work gloves to improve your grip on the unit's handle. Wear snug-fitting clothes that also permit freedom of movement. NEVER wear shorts!

Always wear eye protection such as goggles or safety glasses. Wear hearing protection devices.

Always operate with both hands firmly gripping the unit.

Keep a proper footing and do not overreach—maintain your balance at all times during operation.



Wear sturdy footwear with nonslip soles to provide good footing. Steel-toed safety boots are recommended. Never operate unit bare-footed!

Be aware of the working environment

Make sure bystanders or observers outside the 15 meters (50 feet) "danger zone" wear eye protection.



Reduce the risk of bystanders being struck by flying debris. Make sure no one is within 15 meters—that's about 16 paces—of an operating attachment.

Be extremely careful of slippery terrain, especially during rainy weather.

Avoid long-term operation in very hot or very cold weather.

If contact is made with a hard object, stop the engine and inspect the cutting attachment for damage.

Do not operate the tiller/cultivator in standing water.

Maintain a shallow working angle and avoid steep angles of operation. A steep working angle risks loss of control of the machine.

Be constantly alert for objects and debris that could be thrown either from the rotating cutting attachment or bounced from a hard surface.

Never operate the tiller/cultivator around vines or roots that could tangle in the tines and cause loss of control.

When operating in rocky terrain or near electric wires or fences, use extreme caution to avoid contacting such items with the cultivator tines.

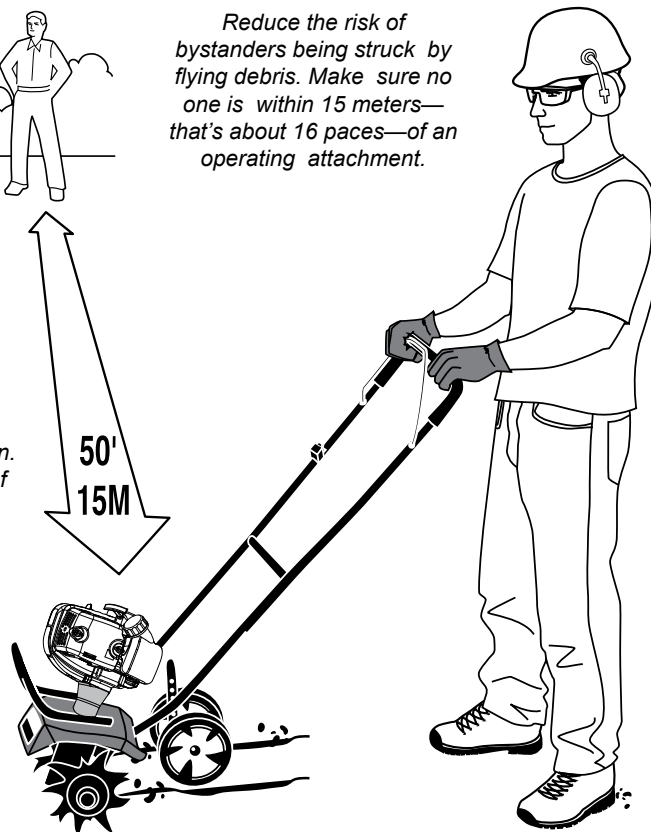

Product Description

Using the illustration as a guide, familiarize yourself with your machine and its various components. Understanding your machine helps ensure top performance, long service life and safer operation.

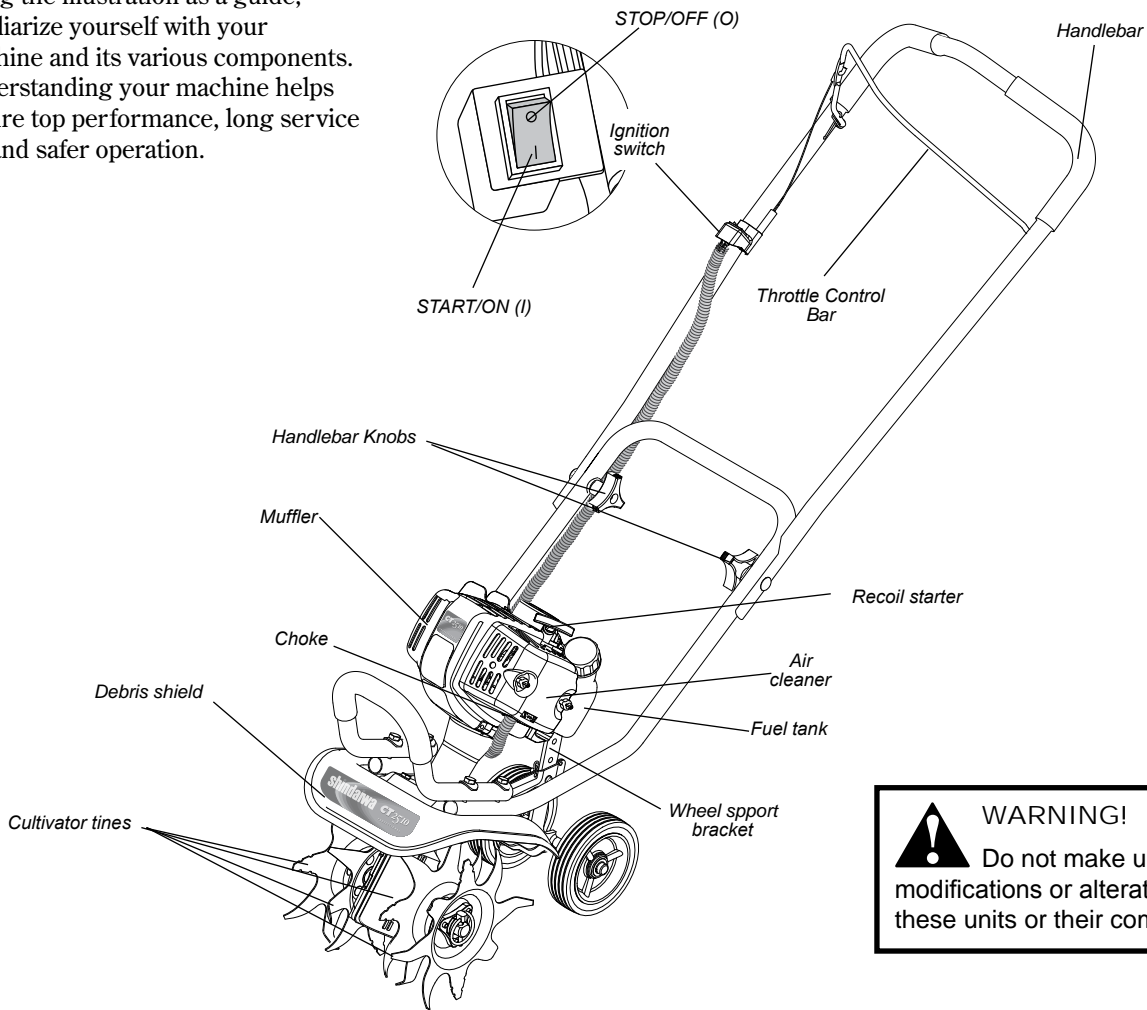

Specifications

Engine model	SF2510E
Dry weight	12.8 kg / 28.4 lbs.
Engine type	4-cycle, air cooled, vertical cylinder
Bore x stroke	34 x27 mm / 1.3 x 1.1 in.
Displacement	24.5 cc / 1.5 cu. in.
Maximum power	1.1 HP/0.8 kW @ 8000 rpm (min ⁻¹)
Fuel/oil ratio	50:1 with ISO-L-EGD or JASO FC class 2-cycle mixing oil*
Carburetor type	Walbro WYL, JX-2407J carburetor with primer
Fuel tank capacity	590 ml / 20.0 oz.
Ignition	One-piece electronic, transistor controlled
Spark plug	NGK CMR5H
Air cleaner type	Non-reversible heavy-duty filter element
Starting method	Recoil
Stopping method	Ignition switch
Transmission type	Automatic, centrifugal clutch w/bevel gear
Cultivator Path Width (max)	22.86 cm / 9 in.
Cultivating Depth (max)	15.24 cm / 6 in.
Coverage Swath width	22.86 cm. / 9 in.
Max coverage area	232.26 sq. m. / 2500 sq ft.
Gear lubrication	Lithium based grease
EPA Emission Compliance Period**	Category A

Specifications are subject to change without notice.

*Shindaiwa C4 Engine Oil meets or exceeds these specifications and is recommended for all Shindaiwa products.

** The EPA emission compliance referred to on the emission compliance label located on the engine, indicates the number of operating hours for which the engine has been shown to meet Federal emission requirements. Category C = 50 hours (Moderate), B = 125 hours (Intermediate) and A = 300 hours (Extended).

Setup and adjustments

Your Shindaiwa cultivator comes completely assembled. You only need to position and secure the handlebars, and to adjust the tine depth.



WARNING

Before performing any adjustment, repair, or cleaning work on the unit, ALWAYS make sure the engine and attachments are completely stopped. Disconnect the spark plug wire before performing service or maintenance.

Positioning the Handlebars

1. Loosen the two knobs on the inside of the handlebars.
2. With the unit upright, swing the handlebars up into the operating position.

NOTE:

Take care not to pinch the throttle cable or switch wires when positioning the handlebar.

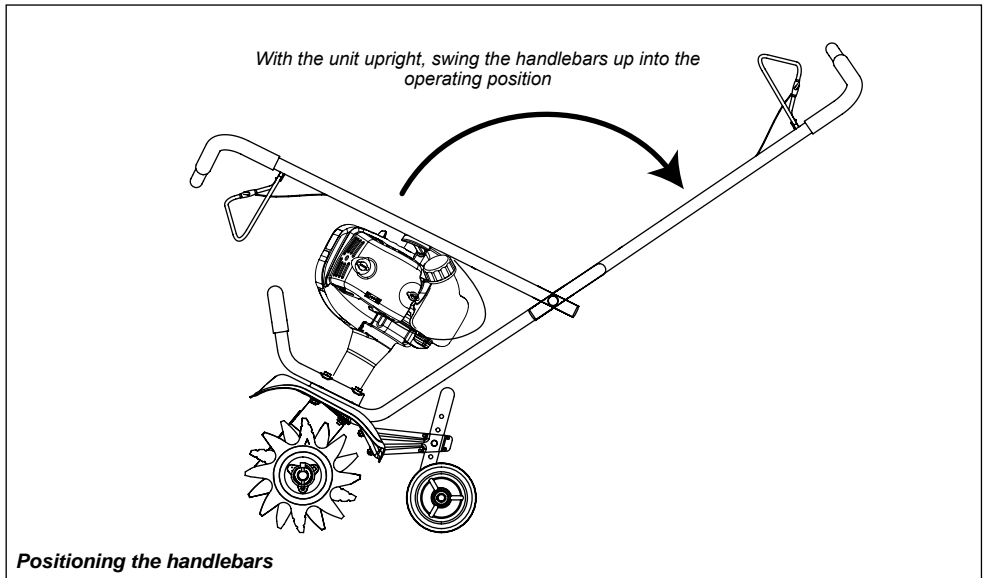

Positioning the handlebars

3. Tighten the knobs to secure the handlebars in place.
4. Reconnect the spark plug wire to the spark plug.

NOTE:

Do not over-tighten the knobs.

Adjusting Tine Depth

To adjust the cultivating depth, proceed as follows:

1. Stop engine and disconnect spark plug to avoid accidental starting.
2. Remove cotter pin from the clevis pin and slide clevis pin out of tailpiece bracket.
3. Slide the wheel support bracket up or down in the tailpiece, aligning the holes to the desire height.
 - Adjust up to **decrease** digging depth.
 - Adjust down to **increase** digging depth.
4. Place the clevis pin through the hole and secure with cotter pin.

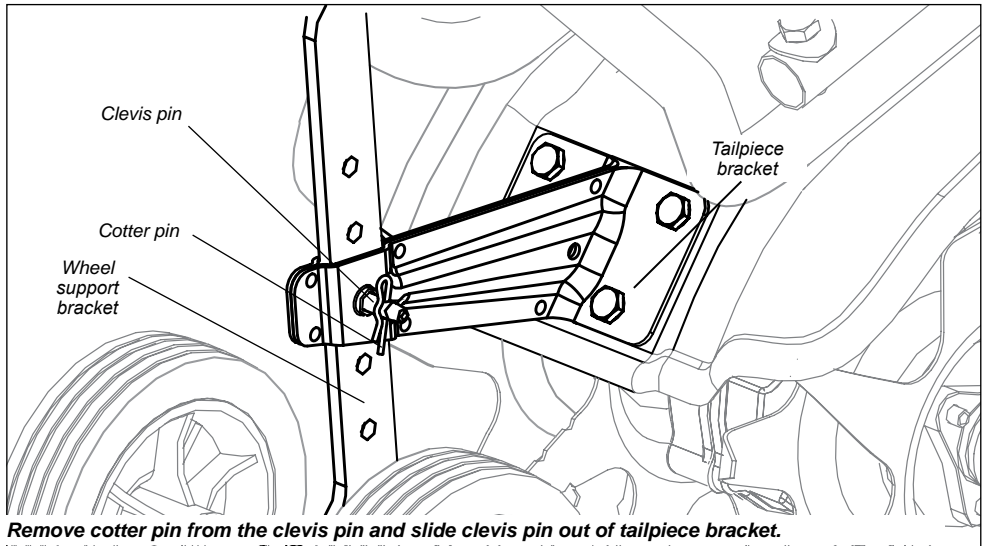

Remove cotter pin from the clevis pin and slide clevis pin out of tailpiece bracket.

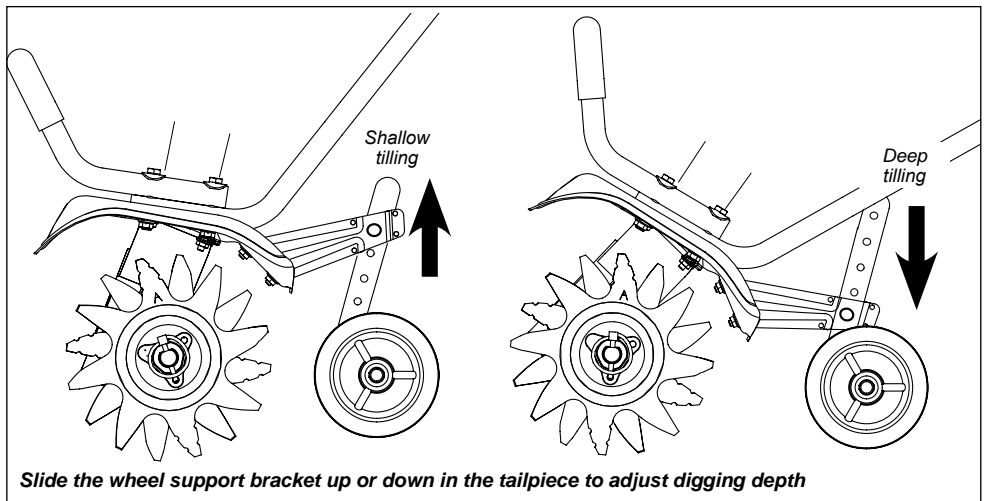

Slide the wheel support bracket up or down in the tailpiece to adjust digging depth

Mixing fuel

CAUTION!

Never use any type of gasoline containing more than 10% alcohol by volume! Some types of gasoline contain alcohol as an oxygenate. Oxygenated gasoline may cause increased operating temperatures. Under certain conditions, alcohol-based gasoline may also reduce the lubricating qualities of some 2-cycle mixing oils.

Generic oils and some outboard oils may not be intended for use in high-performance C4 engines, and should never be used in your Shindaiwa engine.

CAUTION!

This engine is designed to operate on a 50:1 mixture consisting of unleaded gasoline and ISO-L-EGD or JASO FC class 2-cycle mixing oil only. Use of non-approved mixing oils can lead to excessive carbon deposits.

- Use only fresh, clean unleaded gasoline with a pump octane of 87 or higher.
- Mix all fuel with a 2-cycle air-cooled mixing oil that meets or exceeds ISO-L-EGD and/or JASO FC classified oils at 50:1 gasoline/oil ratio.

CAUTION!

Mix and pour fuel outdoors where there are no sparks and flames.

Examples of 50:1 mixing quantities

Gasoline liters	2-cycle mixing oil milliliters
2.5 - 1	50 ml
5 - 1	100 ml
10 - 1	200 ml
20 - 1	400 ml

IMPORTANT!

Mix only enough fuel for your immediate needs! If fuel must be stored longer than 30 days and **ONE** oil with fuel stabilizer is not used, it should first be treated with a fuel stabilizer such as STA-BIL™.



Oil is a registered JASO FC classified oil and also meets or exceeds ISO-L-EGD performance requirements. Shindaiwa One is recommended for use in all Shindaiwa low emissions engines. Shindaiwa One also includes a fuel stabilizer.

Filling the fuel tank



WARNING!

Minimize the Risk of Fire

- **NEVER** smoke or light fires near the engine.
- **ALWAYS** stop the engine and allow it to cool before refueling.
- **ALWAYS** Wipe all spilled fuel and move at least 3 meters (10 feet) from the fueling point and source before starting.
- **NEVER** place flammable material close to the engine muffler.
- **NEVER** operate the engine without the muffler and spark arrester screen in place and in good working condition.

■ FUEL IS HIGHLY FLAMMABLE.

- **ALWAYS** store gasoline in a container approved for flammable liquids.
- **ALWAYS** inspect the unit for fuel leaks before each use. During each refill, check that no fuel leaks from around the fuel cap and/or fuel tank. If fuel leaks are evident, stop using the unit immediately. Fuel leaks must be repaired before using the unit.
- **ALWAYS** move the unit at least 3 meters (10 feet) away from a fuel storage area or other readily flammable materials before starting the engine.

1. Place the unit on a flat, level surface.
2. Clear any dirt or other debris from around the fuel filler cap.

CAUTION!

Slowly remove the fuel cap only after stopping the engine

3. Remove the fuel cap, and fill the tank with clean, fresh fuel.
4. Reinstall the fuel filler cap and tighten firmly.
5. Wipe away any spilled fuel before starting engine.

Starting the Engine

IMPORTANT!!

Engine ignition is controlled by a two position switch mounted below the throttle control bar labeled "I" for ON or START and "O" for OFF or STOP.



WARNING!

- Always start this unit from the operating position. To avoid serious injury, both operator and unit must be in a stable position during engine startup.
- Operate this unit only in a well-ventilated outdoor area. Carbon monoxide exhaust fumes can be lethal in a confined area.
- KEEP CLEAR of tines during starting operations! The drums may rotate during startup, even at engine idle. Keep your hands and your body away from the cutter assembly while starting the engine!

Starting Instructions

1. Put the ignition switch into the ON [I] position.
3. Press the primer bulb until fuel can be seen flowing in the transparent return tube.

IMPORTANT!

The primer system only pushes fuel through the carburetor. Repeatedly pressing the primer bulb will not flood the engine with fuel.

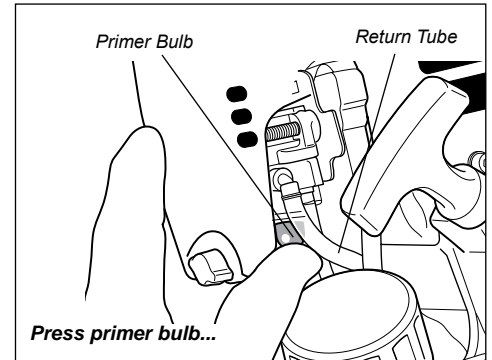
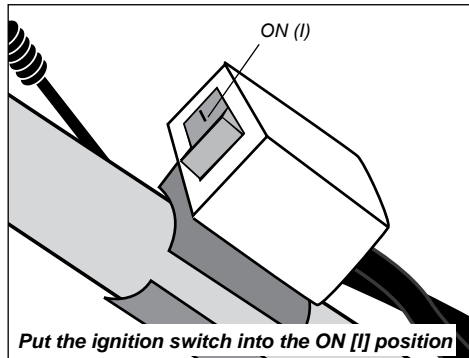

4. Position throttle control bar and choke:
 - a. **Cold engine:** Move the choke into the CLOSED position (|/|). Pull the throttle control bar slightly toward the handlebar with your right hand.
 - b. **Warm engine:** Move the choke into the OPEN position (|+|). Leave the throttle control bar in the idle position.
3. While holding the appropriate throttle position with your right hand, tip the unit back slightly, and brace the cultivator steady with your foot against the wheel, as illustrated.

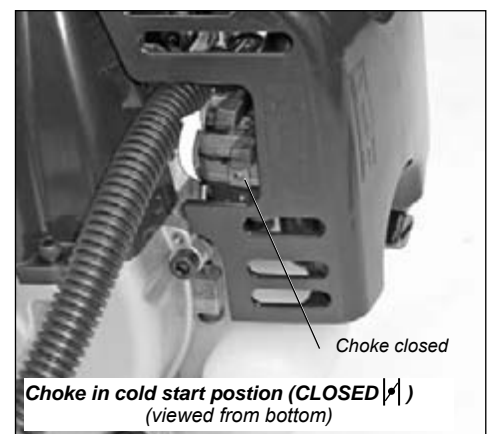
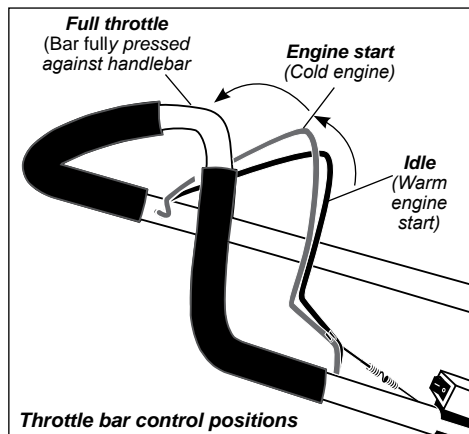

IMPORTANT:

Make sure the tines are off the ground while starting! Squeezing the throttle control bar too much, or too high of an engine idle, can cause the tines to rotate on startup.

4. Use your left hand to slowly pull the recoil starter handle until resistance is felt, then pull quickly to start the engine.

CAUTION!

Do not pull the recoil starter to the end of the rope travel. Pulling the recoil starter to the end of the rope travel can damage the starter.

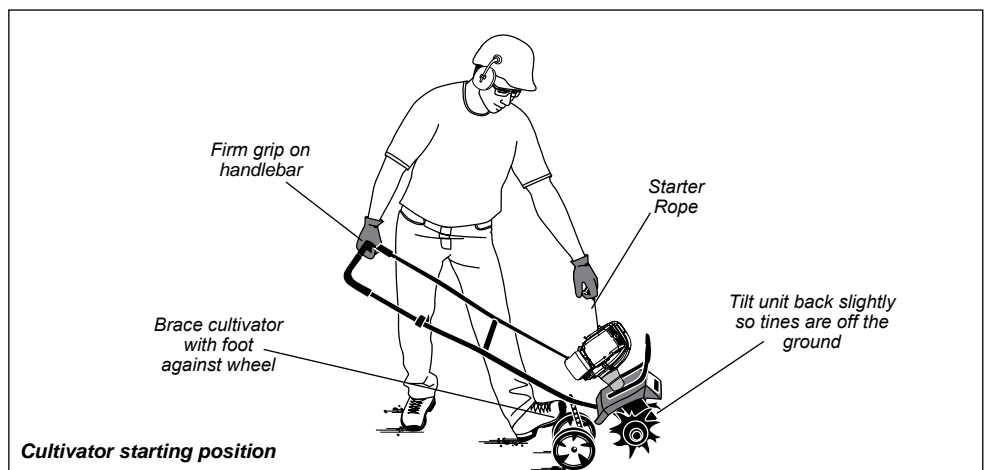

Starting the Engine (continued)

Starting instructions (continued)

- When the engine starts, slowly move the choke lever to the "OPEN" position (|+).
If the engine stops after the initial start, close the choke and restart.

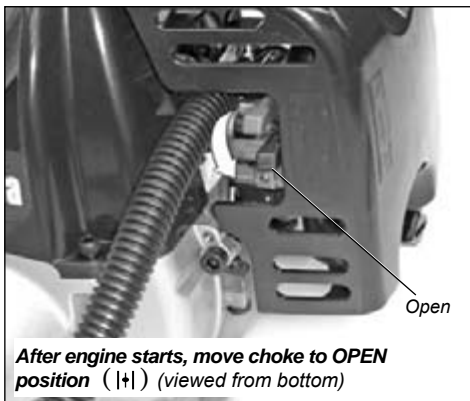

IMPORTANT!

If the engine fails to start after several attempts with the choke in the closed position, the engine may be flooded with fuel. If flooding is suspected, move the choke lever to the open position and repeatedly pull the recoil starter to remove excess fuel and start the engine. If the engine still fails to start, refer to the troubleshooting section of this manual.

When the Engine Starts...

- After the engine starts, allow the engine to warm up at idle 2 or 3 minutes before operating the unit.
- Operate the unit with the throttle control bar fully pressed against the handlebar.
- Releasing the throttle control bar permits the cultivator to stop turning. If the tines continue to rotate when the engine returns to idle, carburetor idle speed should be adjusted. See the section "Adjusting Engine Idle" for the correct procedure.

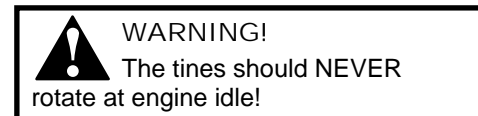

Starting A Flooded Engine

- Disconnect the spark plug lead and use the spark plug wrench to remove the spark plug (turn counter clockwise to remove).
- Slide the ignition switch to the "O" (STOP) position.
 - If the spark plug is fouled or soaked with fuel, clean the plug as necessary.
- Open the choke and fully depress the throttle lever with your left hand, then pull the starter handle rapidly with your right hand to clear excess fuel from the combustion chamber.
- Reinstall the spark plug and tighten it firmly. If a torque wrench is available, torque the spark plug to 10 -15 N•m (88 - 132 lb.-in.).
- Repeat the starting procedure for a warm engine.
- If the engine still fails to start, refer to the troubleshooting section near the end of this manual.

Stopping the Engine

Idle the engine briefly before stopping (about 2 minutes), then click the ignition switch to the "O" (OFF) position.

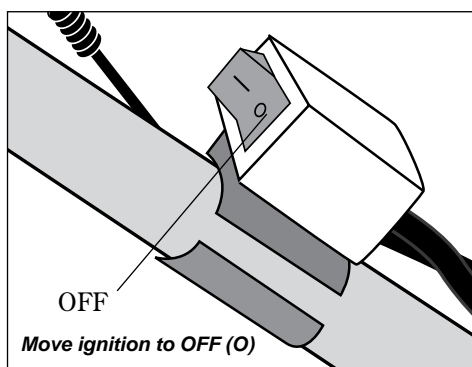
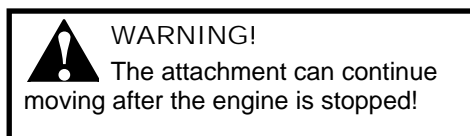

Adjusting Engine Idle

The engine must return to idle speed whenever the throttle lever is released. Idle speed is adjustable, and must be set low enough to permit the engine clutch to disengage the cultivator assembly.



WARNING!

The cultivator assembly must **NEVER** rotate at engine idle! If the idle speed cannot be adjusted by the procedure described here, return the trimmer to your Shindaiwa dealer for inspection.

Idle Speed Adjustment

1. Place the unit on the ground, then start the engine, and then allow it to idle 2-3 minutes until warm.
2. If the attachment rotates when the engine is at idle, reduce the idle speed by turning the idle adjustment screw counter-clockwise.
3. If a tachometer is available, the engine idle speed should be final adjusted to 3,000 (± 300) min^{-1} (rpm).

NOTE

Carburetor fuel mixture adjustments are preset at factory and cannot be serviced in the field.

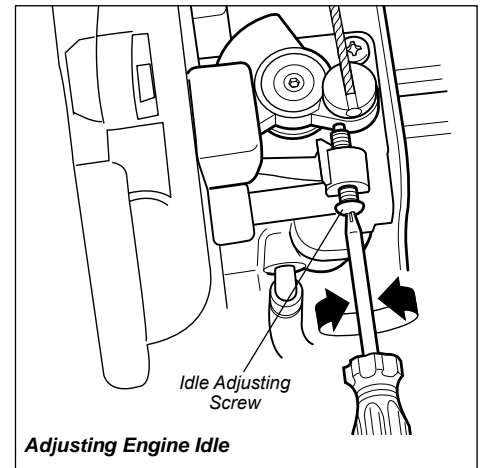

Checking Unit Condition

NEVER operate the unit with the protective devices (ignition switch, etc.) removed!

ALWAYS make sure the tool attachment is properly installed and firmly tightened before operation.

Use only authorized Shindaiwa parts and accessories with your Shindaiwa Cultivator. Do not make modifications to your machine without the written approval of Shindaiwa.

NEVER use a cracked or warped tine: replace it with a serviceable one. For instructions on replacing tines, refer to

“Tine Removal and Replacement” in the Maintenance section of this manual.

ALWAYS stop the engine immediately and check for damage if you strike a foreign object or if the machine becomes tangled. Do not operate with broken or damaged equipment.

NEVER allow the engine to run at high RPM without a load. Doing so could damage the engine.

NEVER operate a machine with worn or damaged fasteners or attachment holders.



WARNING!

A debris shield is no guarantee of protection against ricochet. **YOU MUST ALWAYS GUARD AGAINST FLYING DEBRIS!**

Operation

Using the cultivator



WARNING

Prevent serious personal injuries!

- Dress properly to reduce the risk of injury when operating this unit. Do not wear loose clothing or jewelry. Wear eye and ear/hearing protection. Wear heavy long pants, boots and gloves. Do not wear short pants, sandals or operate barefoot.
- To prevent serious personal injury, never pick up or carry the unit while the engine is running.
- To prevent serious personal injury, use extreme caution when reversing or pulling the unit towards you.
- To prevent serious personal injury, always stop the engine when operation is delayed or when transporting the unit from one location to another.
- Be careful when operating on a slope or slippery terrain, especially during rainy weather.
- Never operate this machine around buried electrical cables!
- **Do not** operate the cultivator in standing water.
- Transport the machine with the engine OFF.
- If the tines jam, switch the engine OFF, disconnect the spark plug lead, and inspect the tines, axles and gearcase for damage.
- Never operate the unit around vines or roots that could tangle in the tines and cause loss of control.
- Maintain a shallow working angle and avoid steep angles of operation. A steep working angle risks loss of control of the machine.

Instructions for safe operation

1. Move the cultivator to the work area prior to starting the engine. Transport the cultivator by pushing or pulling it along on its wheels.
2. Start the unit by following the Starting Instructions.
3. With the engine running and the tines off the ground, depress the throttle control to increase the engine speed.
4. While holding the upper handle with both hands, slowly lower the cultivator until the tines make contact with the ground.
5. As cultivating action begins, tilt the cultivator up slightly using the handle so that the tines can penetrate the ground.
6. Once the ground has been broken, continue at a moderate pace until you are familiar with the controls and the handling of the cultivator.

NOTE

If the tines are digging too deep or not deep enough, adjust the wheel bracket as described in the section, "Adjusting Tine Depth".

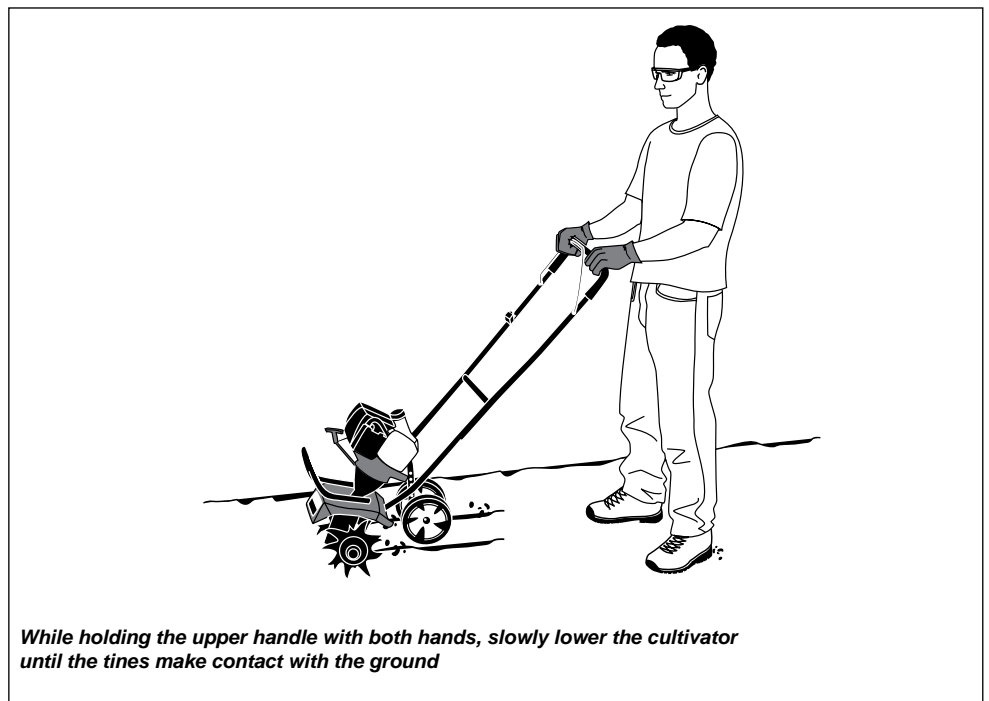

While holding the upper handle with both hands, slowly lower the cultivator until the tines make contact with the ground

Operating tips

1. **WATER** the area to be tilled at least 24 hours before your planned tilling operation; then water again about 3 hours before the actual tilling.
2. **PULL** the unit slowly toward you when tilling or cultivating

Use the correct method for the job:

- **FOR DEEP TILLING** (up to 25 cm / 10" depth), use full throttle while slowly rocking the tiller back and forth over the work area

- **SHALLOW WEEDING** in soft soils is easiest when using a gentle rocking motion.

Transporting the Unit

On site:

- Stop the engine.
- Tilt the unit back until the tines clear the ground.

- Push or pull the unit to the next location to be cultivated.

Transporting in a vehicle:

- Always make sure the engine is stopped.

- Loosen the handle knobs and swing down the handle to create a more compact profile for moving and/or storage.
- Always make sure the unit is well secured in your vehicle to prevent fuel spillage and damage..

Maintenance

General Maintenance

IMPORTANT!

MAINTENANCE, REPLACEMENT OR REPAIR OF EMISSION CONTROL DEVICES AND SYSTEMS MAY BE PERFORMED BY ANY REPAIR ESTABLISHMENT OR INDIVIDUAL; HOWEVER, WARRANTY REPAIRS MUST BE PERFORMED BY A DEALER OR SERVICE CENTER AUTHORIZED BY SHINDAIWA INC. THE USE OF PARTS THAT ARE NOT EQUIVALENT IN PERFORMANCE AND DURABILITY TO AUTHORIZED PARTS MAY IMPAIR THE EFFECTIVENESS OF THE EMISSION CONTROL SYSTEM AND MAY HAVE A BEARING ON THE OUTCOME OF A WARRANTY CLAIM.



WARNING!

Non-standard accessories, cutting attachment, or replacement parts may not operate properly with your unit and may cause damage and lead to personal injury.



WARNING!

Before performing any maintenance, repair, or cleaning work on the unit, make sure the engine and cutting attachment are completely stopped. Disconnect the spark plug wire before performing service or maintenance.

Muffler

This unit must never be operated with a faulty or missing spark arrester or muffler. Make sure the muffler is well secured and in good condition. A worn or damaged muffler is a fire hazard and may also cause hearing loss.

Spark Plug

Keep the spark plug and wire connections tight and clean.

Fasteners

Make sure nuts, bolts, and screws (except carburetor adjusting screws) are tight.

Air Filter

The C4 engine that powers your Shindaiwa model is a hybrid 4-stroke engine. As a hybrid, the engine is lubricated by oil mixed with the gasoline and air from the carburetor that moves through and around the internal parts of the engine in a similar way that a 2-stroke engine is lubricated. Without the heavy duty 2-stage air filter equipped on all C4 engines, dust and dirt could also move through the engine, decreasing engine life, increasing valve wear and the need for more frequent valve adjustments.

To keep your C4 engine strong and reliable, Shindaiwa recommends that you check and service the air filter as instructed in the 10-Hour Maintenance section that follows.

Cultivator tines

Check tine condition frequently. If a tine's performance changes suddenly, stop the engine and check the tine for cracks or other damage. Replace a damaged tine IMMEDIATELY!



WARNING!

Never repair a damaged cultivator tine by welding, straightening, or by modifying its shape. An altered tine may break during operation, resulting in serious personal injury.

Daily Maintenance

Prior to each work day, perform the following:

- Remove all dirt and debris from the engine, check the cooling fins and air cleaner for clogging, and clean as necessary.
- Clean any debris or dirt from the cultivator tines.

- Check the entire unit for leaking fuel or grease.
- Check for loose or missing screws or components. Make sure the handles and attachments are securely fastened.
- Make sure nuts, bolts, and screws (except carburetor idle speed adjusting screws) are tight.

- Carefully remove any accumulations of dirt or debris from the muffler and fuel tank. Check cooling air intake area at base of crankcase. Remove all debris. Dirt build-up in these areas can lead to engine overheating, fire, or premature wear.

NOTE

Cleaning encrusted soil or removing strands of weeds or roots from the tines is quicker with the tines removed from the shaft. Tine removal and replacement is quick and simple. See the section "Tine Removal and Replacement" for the correct procedure.

Maintenance (continued)

10-Hour Maintenance

(more frequently in dusty conditions)

1. Remove the air cleaner cover by loosening the thumbscrews and lifting.
2. Remove and inspect the pre-filter. If the pre-filter is torn or otherwise damaged, replace it with a new one.
3. Clean the pre-filter with soap and water. Let dry before reinstalling.
4. Inspect the air filter element. If the element is damaged or distorted, replace it with a new one.
5. Tap filter gently on a hard surface to dislodge debris from element or use compressed air from the inside to blow debris out and away from the air filter element.
6. Install the air filter element, pre-filter and cover in the reverse order of removal.

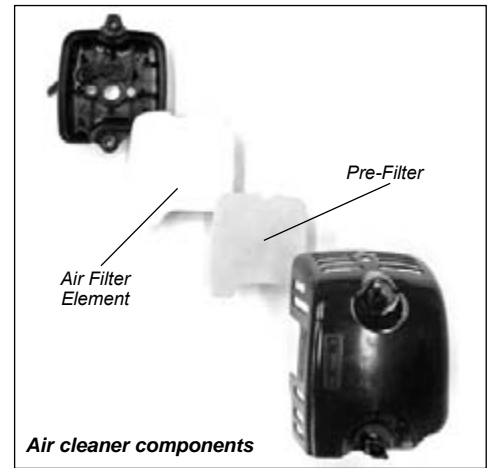
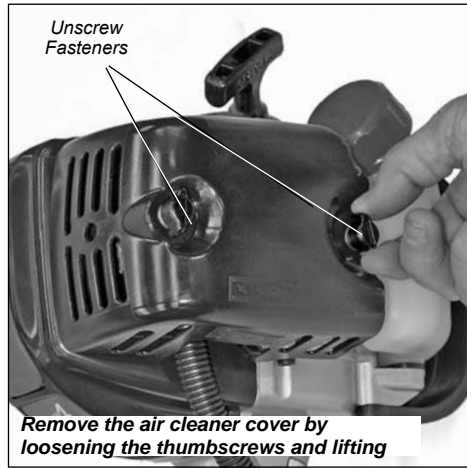

IMPORTANT!

Direct the air stream at the inside face of the filter only!

CAUTION!

Never operate the unit if the air cleaner assembly is damaged or missing!

10/15-Hour Maintenance

Remove and clean or replace the spark plug.

- Adjust the spark plug electrode gap to 0.6-0.7 mm. If the spark plug must be replaced, use only an NGK CMR5H or equivalent resistor type spark plug of the correct heat range.

CAUTION!

Before removing the spark plug, clean the area around the plug to prevent dirt and debris from getting into the engine's internal parts.

NOTE:

The NGK CMR5H also meets the requirements for electro magnetic compliance (EMC).

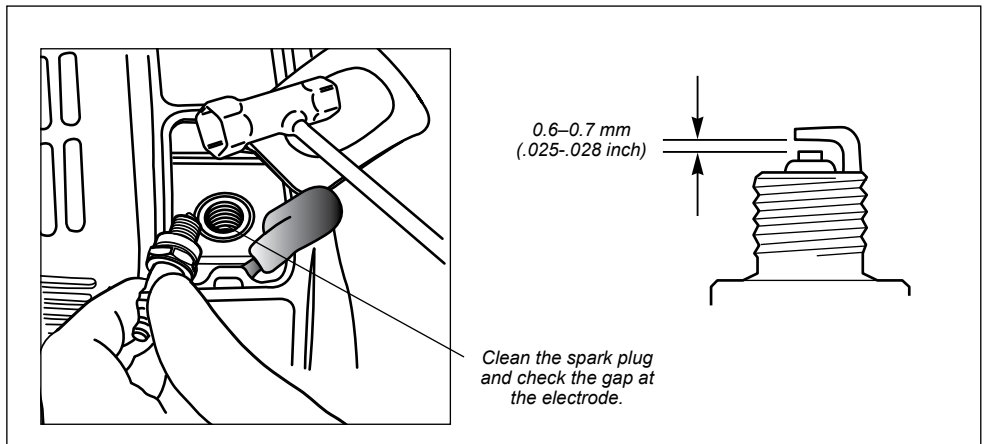

Maintenance (continued)

50-hour Maintenance

Remove and replace the fuel filter element.

- Use a hooked wire to extract the fuel filter from inside the fuel tank. Inspect the fuel filter element. If it shows signs of contamination, replace with a genuine Shindaiwa replacement fuel filter element.

CAUTION!

Make sure you do not pierce the fuel line with the end of the hooked wire. The line is delicate and can be damaged easily.

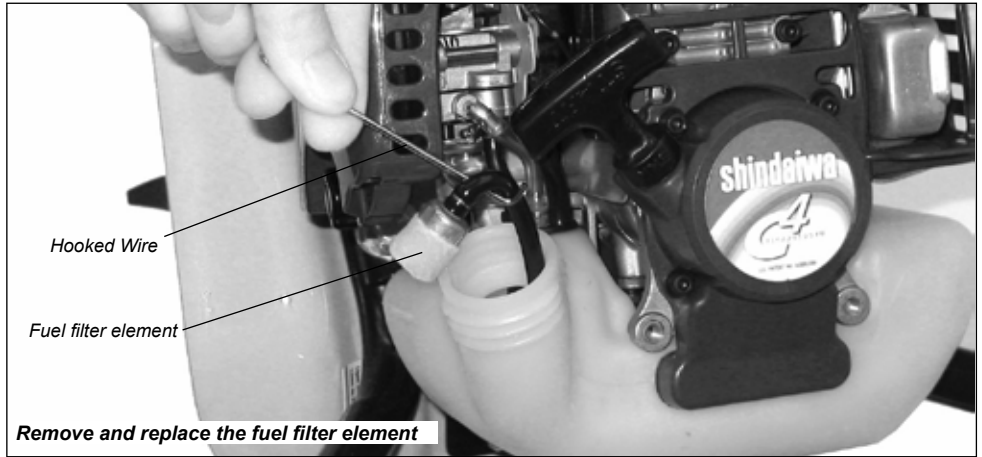

Before reinstalling the new filter element, inspect the condition of all the fuel system components (fuel pick-up line, fuel return line, tank vent line, tank vent, fuel cap and fuel tank).

If damage, splitting or deterioration is noted, the unit should be removed from service until it can be inspected or repaired by a Shindaiwa-trained service technician.

139/150-Hour Maintenance

Maintenance after first 139-hours, then every 150-hours thereafter.

- Combustion chamber should be decarbonized, and the valve clearance should be adjusted. It is highly recommended that this is done by a Shindaiwa-trained service technician.

- Replace the spark plug annually: Use only NGK CMR5H or equivalent resistor type spark plug of the correct heat range. Set spark plug electrode gap to 0.6 -0.7 mm (.025 - .028 inch).

- The valve clearance should be adjusted annually or every 135 hours. It is highly recommended that this is done by a Shindaiwa-trained service technician.

NOTE:

The NGK CMR5H also meets the requirements for electro magnetic compliance (EMC).

Valve adjustment

1. Remove cylinder cover, rocker arm cover, and spark plug. Rotate the crankshaft while observing the piston through the spark plug opening. When the piston is at the top of the compression stroke (TDC), the valves can be adjusted.

CAUTION!

- Performing a valve adjustment incorrectly may cause hard starting and/or can damage the engine.
- If you are unfamiliar with this engine or uncomfortable with this procedure, consult with an authorized Shindaiwa servicing dealer.



2. Loosen adjuster locknut so that the 2.5 mm Allen socket head adjustment screw can turn freely.
3. Insert 0.10 mm (0.004") feeler gauge between valve stem tip and rocker arm.
4. Turn adjustment screw (clockwise = tighter, counter-clockwise = looser) until feeler gauge is almost snug. Back off just enough to allow gauge to slip out with limited resistance.
5. While holding the adjustment screw in place with the Allen driver, tighten the locknut with a wrench.

6. Turn engine over several times, and return to TDC-compression. Recheck with proper feeler gauge to make sure clearance adjustment did not change as a result of tightening the locknut. Readjust as necessary.
7. Replace rocker arm cover gasket to assure proper sealing and install cover.

IMPORTANT!

If a new gasket is not available and/or the old gasket is not damaged, the old gasket may be reused. Never use cracked or damaged gaskets!

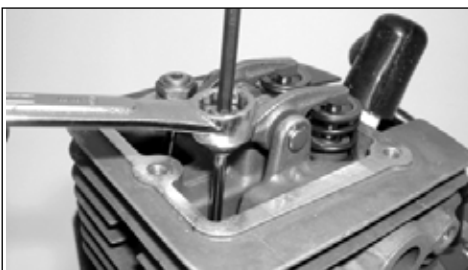

Maintenance (continued)

Tine Removal and Replacement

All four tines should be replaced at the same time because they will wear evenly through normal use. Work on one side at a time.



WARNING!

The tines are sharp! To avoid injury, always wear heavy gloves when performing tine maintenance.

NOTE

To make removal and replacement easier, lay the cultivator back in a horizontal position on a flat, level surface with the upper handle touching the ground.

1. Make sure the ignition switch is in the STOP (O) position and disconnect the spark plug wire.
2. Remove the click pin from each end of the tine shaft. Slide the tines off of the shaft.

NOTE

It may be necessary to wash the dirt off the tines and shaft for ease of removal.

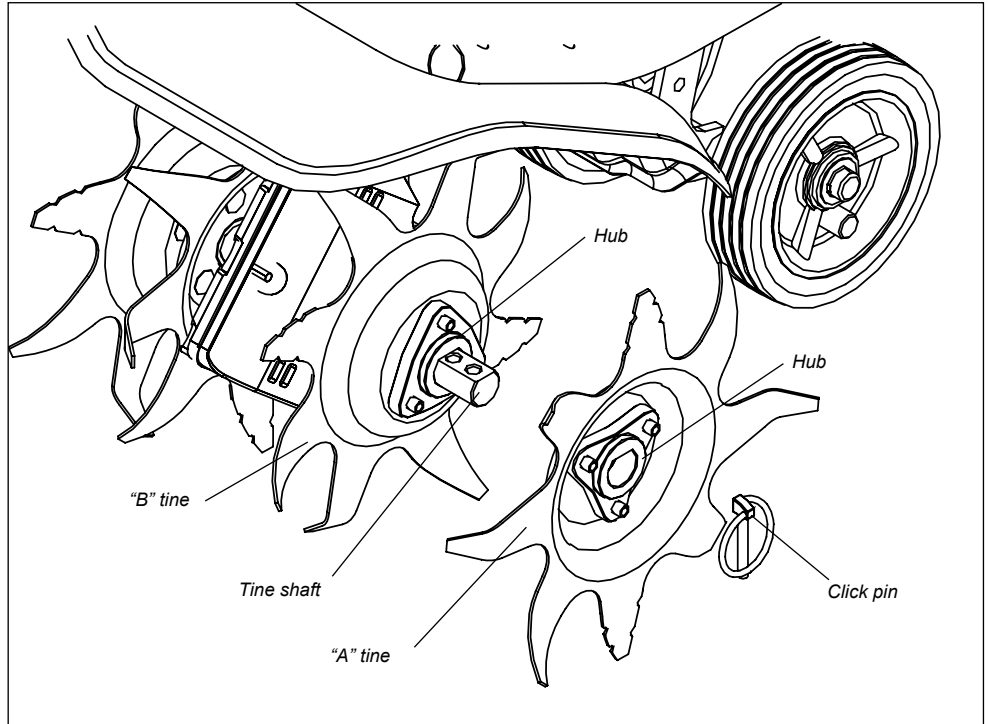

3. Clean and oil the shaft.
4. Slide on the new tines with the hubs facing out. The four tines are marked with the letters "A" or "B."
5. Place one "A" tine and one "B" tine onto the shaft.
6. Secure the new tines to the shaft with click pins.

Long Term Storage

Whenever the unit will not be used for 30 days or longer, use the following procedures to prepare it for storage:

- Clean external parts thoroughly.
- Drain all the fuel from the carburetor and the fuel tank.

IMPORTANT!

All stored fuels should be stabilized with a fuel stabilizer such as STA-BIL.

CAUTION!

Gasoline stored in the carburetor for extended periods can cause hard starting, and could also lead to increased service and maintenance costs.

- Remove remaining fuel from the fuel lines and carburetor with the fuel drained from the fuel tank. To do so:
 1. Prime the primer bulb until no more fuel is passing through.
 2. Start and run the engine until it stops running.
 3. Repeat steps 1 and 2 until the engine will no longer start.

NOTE

Damage caused by stale or contaminated fuel is not covered by the Shindaiwa warranty policy.

- Remove the spark plug and pour about 7 ml (1/4 ounce) of 2-cycle mixing oil into the cylinder through the spark plug hole. Slowly pull the recoil starter 2 or 3 times so oil will evenly coat the interior of the engine. Reinstall the spark plug.
- Before storing the unit, repair or replace any worn or damaged parts.
- Remove the air cleaner element from the carburetor and clean it thoroughly with soap and water, let dry and reassemble the element.
- Loosen the handle knobs and swing down the handle to create a more compact profile for moving and/or storage.
- Store the unit in a clean, dust-free area.

Maintenance (continued)

Muffler Maintenance

If the engine becomes sluggish and low on power, check and clean the spark arrester screen.



WARNING!

Never operate the unit with a damage or missing muffler or spark arrester! Operating with a missing or damaged spark arrester is a fire hazard and could also damage your hearing.

1. With a 3 mm hex wrench remove the 4 engine cover screws and the engine cover.
2. With a 4 mm hex wrench, remove the 3 muffler bolts and the muffler.
3. With a small flat bladed screwdriver remove the two screws holding the spark arrester screen and cover to the muffler.
4. Remove the screen and clean it with a stiff bristle brush.
5. Inspect the cylinder exhaust port for any carbon buildup.
6. Reassemble the spark arrester, muffler and engine cover in the reverse order of disassembly.

IMPORTANT!

If you note excessive carbon buildup, consult with an authorized Shindaiwa servicing dealer.

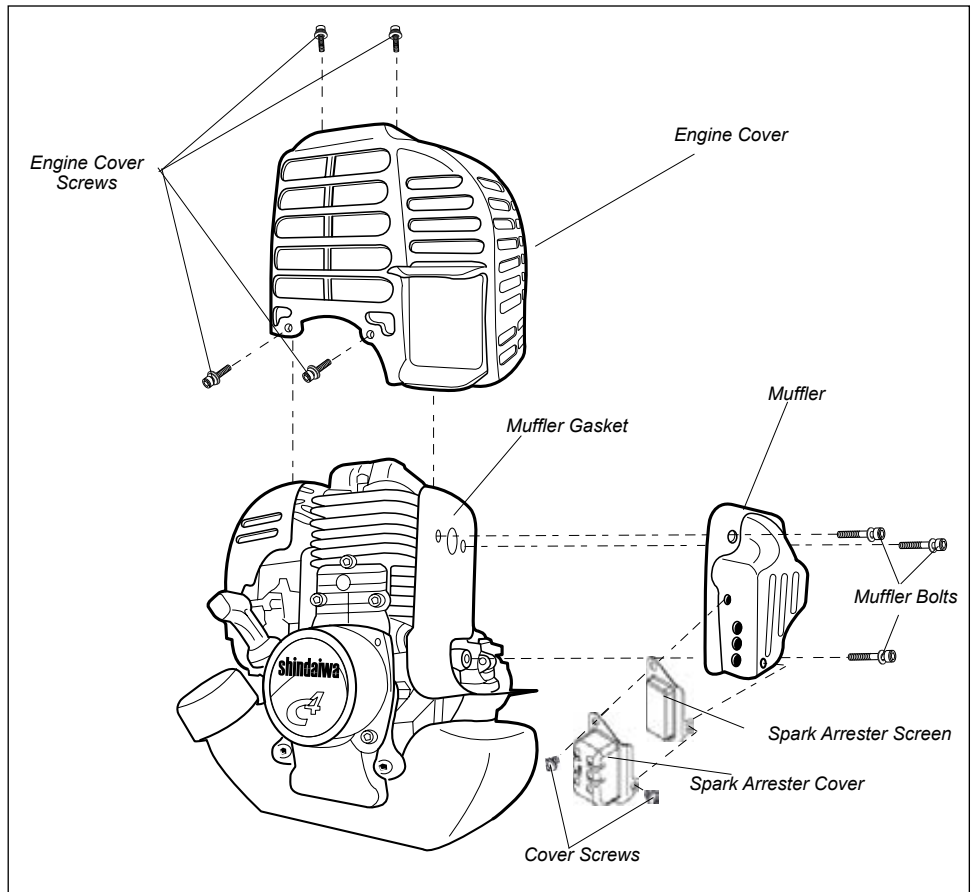

ENGINE DOES NOT START

What To Check	Possible Cause	Remedy
<p>Does the engine crank?</p>	<p>NO → Faulty recoil starter. Fluid in the crankcase. Internal damage.</p>	<p>Consult with an authorized servicing dealer.</p>
<p>YES ↓ Good compression?</p>	<p>NO → Loose spark plug. Excess wear on cylinder, piston, rings.</p>	<p>Tighten and re-test. Consult with an authorized servicing dealer.</p>
<p>YES ↓ Does the tank contain fresh fuel of the proper grade?</p>	<p>NO → Fuel incorrect, stale, or contaminated; mixture incorrect.</p>	<p>Refill with fresh, clean unleaded gasoline with a pump octane of 87 or higher mixed with a 2-cycle mixing oil that meets or exceeds ISO-L-EGD and/or JASO FC classified oils at 50:1 gasoline/oil ratio.</p>
<p>YES ↓ Is fuel visible and moving in the return line when priming?</p>	<p>NO → Check for clogged fuel filter and/or vent.</p>	<p>Replace fuel filter or vent as required. Restart.</p>
<p>YES ↓ Is there spark at the spark plug wire terminal?</p>	<p>NO → The ignition switch is in “O” (OFF) position. Shorted ignition ground. Faulty ignition unit.</p>	<p>Move switch to “I” (ON) position and restart. Consult with an authorized servicing dealer.</p>
<p>YES ↓ Check the spark plug.</p>	<p>If the plug is wet, excess fuel may be in the cylinder. The plug is fouled or improperly gapped. The plug is damaged internally or of the wrong size.</p>	<p>Crank the engine with the plug removed, reinstall the plug, and restart. Clean and regap the plug to 0.6mm - 0.7mm (.025 -.028 inch) . Restart. Replace the spark plug. Check the “Specifications” section for the correct plug for your unit. Restart.</p>

LOW POWER

What To Check	Possible Cause	Remedy
<p>Is the engine overheating?</p>	<p>Operator is overworking the unit.</p> <p>Carburetor mixture is too lean.</p> <p>Improper fuel ratio.</p> <p>Fan, fan cover, cylinder fins dirty or damaged</p>	<p>Operate at slower rate.</p> <p>Consult with an authorized servicing dealer.</p> <p>Refill with fresh, clean unleaded gasoline with a pump octane of 87 or higher mixed with a 2-cycle mixing oil that meets or exceeds ISO-L-EGD and/or JASO FC classified oils at 50:1 gasoline/oil ratio.</p> <p>Clean, repair or replace as necessary.</p>
<p>Engine is rough at all speeds. May also have black smoke and/or unburned fuel at the exhaust.</p>	<p>Carbon deposits on the piston or in the muffler.</p> <p>Clogged air cleaner element.</p> <p>Loose or damaged spark plug.</p> <p>Air leakage or clogged fuel line.</p> <p>Water in the fuel.</p> <p>Piston seizure.</p> <p>Faulty carburetor and/or diaphragm</p>	<p>Consult with an authorized servicing dealer</p> <p>Clean or replace the air filter</p> <p>Tighten or replace the spark plug. Restart. Check the Product Specifications page in this manual for the correct spark plug for this unit.</p> <p>Repair or replace fuel filter and/or fuel line.</p> <p>Refill with fresh fuel/oil mixture.</p> <p>Consult with an authorized servicing dealer.</p>
<p>Engine is knocking.</p>	<p>Overheating condition.</p> <p>Improper fuel.</p> <p>Carbon deposits in the combustion chamber.</p> <p>Valve clearance set incorrectly.</p>	<p>Consult with an authorized servicing dealer.</p> <p>Check fuel octane rating; check for presence of alcohol in the fuel. Refuel as necessary.</p> <p>Consult with an authorized servicing dealer.</p>

Troubleshooting Guide (continued)

ADDITIONAL PROBLEMS

What To Check	Possible Cause	Remedy
Poor acceleration.	<ul style="list-style-type: none"> Clogged air filter. Clogged fuel filter. Lean fuel/air mixture. Idle speed set too low. 	<ul style="list-style-type: none"> Clean or replace the air filter. Replace the fuel filter. Consult with an authorized servicing dealer. Adjust: 3,000 (\pm300) min⁻¹.
Engine stops abruptly.	<ul style="list-style-type: none"> Switch turned off. Fuel tank empty. Clogged fuel filter. Water in the fuel. Shorted spark plug or loose terminal. Ignition failure. Piston seizure. 	<ul style="list-style-type: none"> Reset the switch and re-start. Refuel. See Fuel section of manual. Replace fuel filter. Drain; replace with clean fuel. See Fuel section of manual. Clean or replace spark plug. Check the Specifications page in this manual for the proper spark plug for your unit. Tighten the terminal. Replace the ignition unit. Consult with an authorized servicing dealer
Engine difficult to shut off.	<ul style="list-style-type: none"> Ground (stop) wire is disconnected or switch is defective Overheating due to incorrect spark plug Overheated engine. 	<ul style="list-style-type: none"> Test and replace as required. Replace the spark plug. Check the Specifications page in this manual for the proper spark plug for your unit. Idle engine until cool.
Top of engine is getting dirty and oily.	<ul style="list-style-type: none"> Valve cover is leaking. 	<ul style="list-style-type: none"> Consult with an authorized servicing dealer.
Engine will not idle down.	<ul style="list-style-type: none"> Idle set too high. Engine has an air leak. 	<ul style="list-style-type: none"> Set idle: 3,000 (\pm300) min⁻¹. Consult with an authorized servicing dealer.
Tines rotates at engine idle.	<ul style="list-style-type: none"> Engine idle too high. Broken clutch spring or worn clutch spring boss. Loose attachment holder. 	<ul style="list-style-type: none"> Set idle: 3,000 (\pm300) min⁻¹. Replace spring/shoes as required, check idle speed. Inspect and re-tighten holders securely.
Excessive vibration.	<ul style="list-style-type: none"> Warped or damaged attachment. Loose gearcase. Bent main shaft/worn or damaged bushings. 	<ul style="list-style-type: none"> Inspect and replace attachment as required. Tighten gearcase securely. Inspect and replace as necessary.
Tines will not rotate.	<ul style="list-style-type: none"> Shaft not installed in powerhead or gearcase. Broken shaft. Damaged gearcase. Vegetation or dirt obstructing movement. 	<ul style="list-style-type: none"> Inspect and reinstall as required. Consult with a authorized servicing dealer. Clear obstruction(s). If necessary, remove the tines to clean. Follow procedure in "Removing and Replacing Tines."

Emission System Warranty Statement

Your Warranty Rights and Obligations

The California Air Resources Board, the U.S. Environmental Protection Agency and Shindaiwa Inc. are pleased to explain the exhaust and evaporative emission control system warranty on your new small off-road (non-road) engine.

In California, new small off-road engines must be designed, built, and equipped to meet the State's stringent anti-smog standards. In other states, new 1997 and later non-road engines must meet the Federal EPA's stringent anti-smog standards.

Shindaiwa Inc. must warrant the emission control system on your small off-road engine for the periods of time listed below, provided there has been no abuse, neglect, or improper maintenance of your small off-road engine.

Your engine exhaust and evaporative emission control system includes parts such as the carburetor, fuel tank, the ignition system and, if equipped, the catalytic converter. These components are specifically listed below.

Where a warrantable condition exists, Shindaiwa Inc. will repair your small off-road engine at no cost to you including diagnosis, parts, and labor.

Manufacturer's Warranty Coverage

When sold within the U.S., this engine's emission control system is warranted for a period of two (2) years from the date this product is first delivered to the original retail purchaser.

During the warranty period, Shindaiwa Inc. will, at their option, repair or replace any defective emission-related component on this engine. During the original Warranty Period, these Warranty Rights are automatically transferable to subsequent owners of this product.

What is Covered by this Warranty

1. Carburetor Internal Components

- Throttle Valve, Needle, Jet, Metering Diaphragm

2. Fuel Tank

3. Ignition System Components

- Ignition Coil
- Flywheel Rotor

4. Catalytic Converter (if originally equipped)

The emission control system for your particular Shindaiwa engine may also include certain related hoses and connectors.

Owners Warranty Responsibilities

As the small off-road engine owner, you are responsible for the performance of the required maintenance listed in this owners manual. Shindaiwa Inc. recommends that you retain all receipts covering maintenance on your small off-road engine, but Shindaiwa Inc. cannot deny warranty solely for the lack of receipts or for your failure to ensure the performance of all scheduled maintenance.

As the small off-road engine owner, you should be aware, however, that Shindaiwa Inc. may deny you warranty coverage if your small off-road engine or a part has failed due to abuse, neglect, improper maintenance, or unapproved modifications.

You are responsible for presenting your small off-road engine to an authorized Shindaiwa Dealer as soon as a problem exists. The warranty repairs should be completed in a reasonable amount of time, not to exceed 30 days.

If you have any questions regarding your warranty rights and responsibilities, you should contact a Shindaiwa customer service representative at (503) 692-3070 or your local Shindaiwa Dealer.

Consequential Damages

In the event that other component parts of this product are damaged by the failure of a warranted part, Shindaiwa Inc. will repair or replace such component parts at no charge to you.

What is Not Covered

- Failures caused by abuse, neglect, or improper maintenance procedures.
- Failures caused by the use of modified or non-approved parts or attachments.

This Warranty is Administered by:

Shindaiwa Inc.
11975 S.W. Herman Rd.
Tualatin, OR 97062
(503) 692-3070

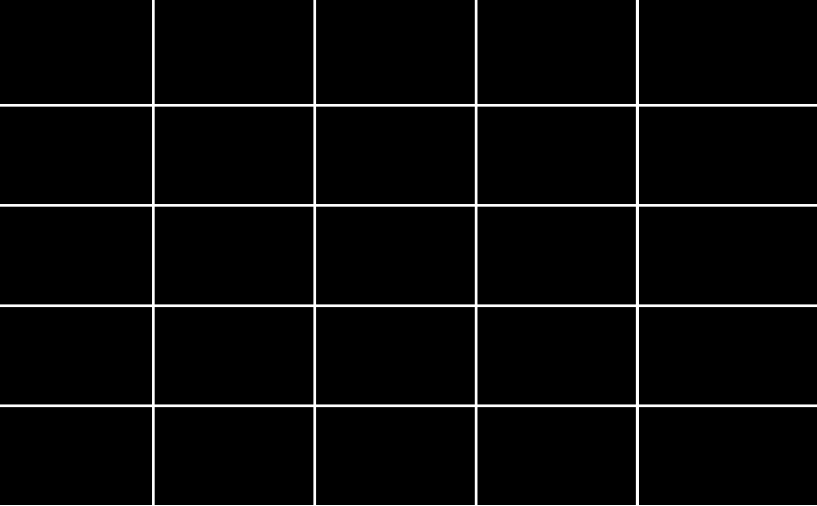

shindaiwa®

Shindaiwa Inc.
11975 S.W. Herman Rd.
Tualatin, Oregon 97062
Telephone: 503 692-3070
Fax: 503 692-6696
www.shindaiwa.com

Shindaiwa Corporation
Head Office: 6-2-11 Ozuka
Nishi, Asaminami-ku
Hiroshima, 731-3167, Japan
Telephone: 81-82-849-2220
Fax: 81-82-849-2481

©2008 Shindaiwa, Inc.
Part Number 89226
Revision 12/08
Shindaiwa is a registered trademark of Shindaiwa, Inc.
Specifications subject to change without notice.